

- 60, 85, 110, 165, 200, 250, 300, 350 and 400mm mounting widths are available.
- Available angles are from 0° to 75° in increments of 5°.
- Gas spring can be removed from the cam whilst in the die/press.
- Complying with VDI-BAK specification.

UCMSV Specifications

Mounting width	Surface height	Working Angle	Travel	Working Force kN(tonf)	Mounting width	Surface height	Working Angle	Travel	Working Force kN(tonf)	Mounting width	Surface height	Working Angle	Travel	Working Force kN(tonf)
60	225	00	19.3	75 (7.6)	165	300	00	32.1	171 (17.5)	300	375	00	38.6	364 (37.1)
		05	21.3				05	35.5				05	42.6	
		10	23.3				10	38.9				10	46.7	
		15	25.4				15	42.4				15	50.9	
		20	27.6				20	46.1				20	55.3	
		25	30.0				25	50.0				25	60.0	
		30	32.6				30	54.3				30	65.1	
		35	35.4				35	59.0				35	70.8	
		40	38.6				40	64.3				40	77.1	
		45	42.3				45	70.4				45	84.5	
		50	46.7				50	77.8				50	93.3	
		55	52.3				55	87.2				55	104.6	
		60	60.0				60	100.0				60	120.0	
		65	71.0				65	130.0				65	146.6	
		70	81.9				70	168.5				70	173.1	
75	108.2	75	227.3	75	233.6									
85	225	00	19.3	100 (10.2)	200	300	00	32.1	218 (22.2)	350	375	00	38.6	405 (41.3)
		05	21.3				05	35.5				05	42.6	
		10	23.3				10	38.9				10	46.7	
		15	25.4				15	42.4				15	50.9	
		20	27.6				20	46.1				20	55.3	
		25	30.0				25	50.0				25	60.0	
		30	32.6				30	54.3				30	65.1	
		35	35.4				35	59.0				35	70.8	
		40	38.6				40	64.3				40	77.1	
		45	42.3				45	70.4				45	84.5	
		50	46.7				50	77.8				50	93.3	
		55	52.3				55	87.2				55	104.6	
		60	60.0				60	100.0				60	120.0	
		65	71.0				65	130.0				65	146.6	
		70	81.9				70	168.5				70	173.1	
75	108.2	75	227.3	75	233.6									
110	275	00	32.1	150 (15.3)	250	300	00	32.1	284 (29.0)	400	375	00	38.6	450 (45.9)
		05	35.5				05	35.5				05	42.6	
		10	38.9				10	38.9				10	46.7	
		15	42.4				15	42.4				15	50.9	
		20	46.1				20	46.1				20	55.3	
		25	50.0				25	50.0				25	60.0	
		30	54.3				30	54.3				30	65.1	
		35	59.0				35	59.0				35	70.8	
		40	64.3				40	64.3				40	77.1	
		45	70.4				45	70.4				45	84.5	
		50	77.8				50	77.8				50	93.3	
		55	87.2				55	87.2				55	104.6	
		60	100.0				60	100.0				60	120.0	
		65	116.6				65	116.6				65	136.6	
		70	133.1				70	133.1				70	153.1	
75	159.6	75	159.6	75	169.6									

UCMSV60/85/110 Structure and Assembly / Disassembly

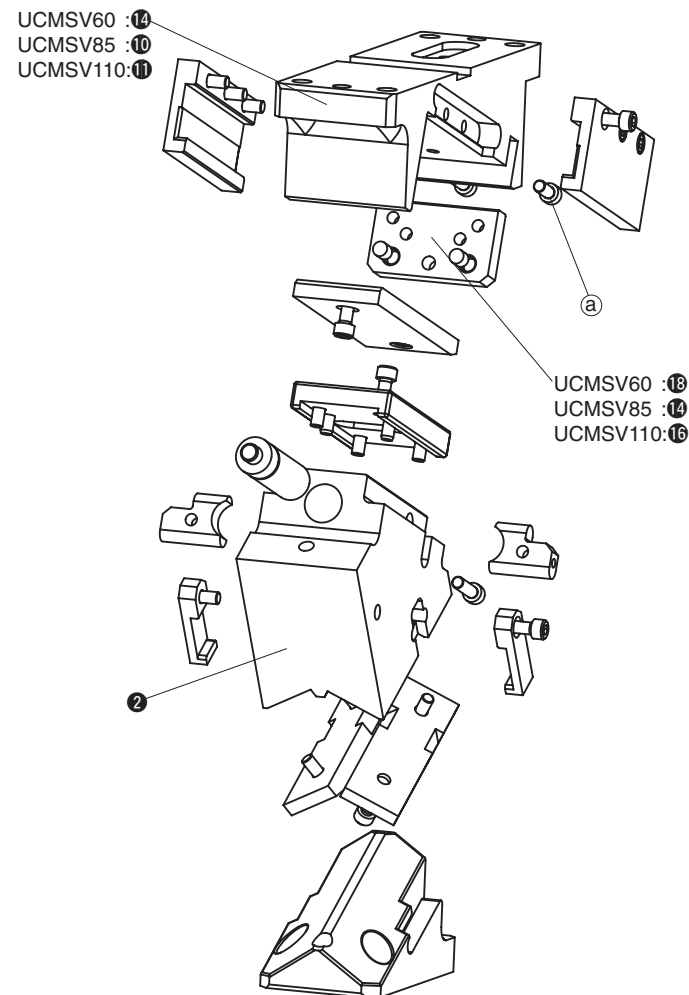

Disassembly method of UCMSV 60 / 85 / 110

- 1) Remove hexagon socket head bolt (a) and stopper plate (UCMSV60: 18, UCMSV85: 14, UCMSV110: 16).
- 2) Remove cam slider (2) from cam holder (UCMSV60: 14, UCMSV85: 10, UCMSV110: 11) at rear of cam.

Assembly method of UCMSV 60 / 85 / 110

- 1) Assemble components in the reverse order to which they were removed.
 - Make sure that there is no foreign matter on the slide surfaces before assembly.
 - The clearance between the cam slider and the cam holder is carefully controlled. Check that the serial number stamped on both parts is the same.
 - Please ensure that all bolts removed are re-installed and tightened.

■ UCMSV165/200/250/300/350/400

Structure and Assembly / Disassembly

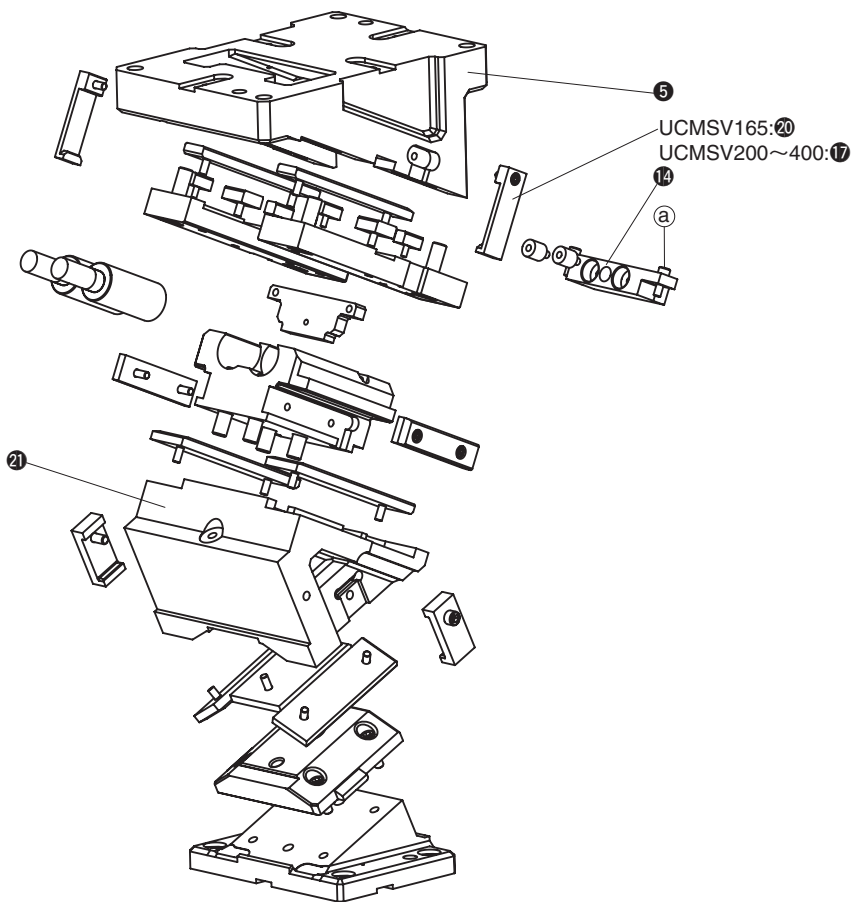

• Disassembly method of UCMSV 165 / 200 / 250 / 300 / 350 / 400

- 1) Remove safety plate (UCMSV165: 20, UCMSV200~400: 17).
- 2) Remove hexagon socket head bolt (20) and stopper plate (14).
- 3) Remove cam slider (21) from cam holder (5) at rear of cam.

• Assembly method of UCMSV 165 / 200 / 250 / 300 / 400

- 1) Assemble components in the reverse order to which they were removed.
 - Make sure that there is no foreign matter on the slide surfaces before assembly.
 - The clearance between the cam slider and the cam holder is carefully controlled. Check that the serial number stamped on both parts is the same.
 - Please ensure that all bolts removed are re-installed and tightened.

■ UCMSV60/85/110 Removing gas spring

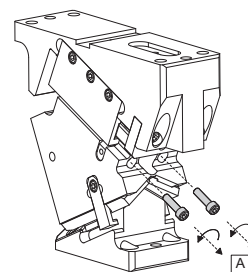

Remove the screws of the spring stopper [A]

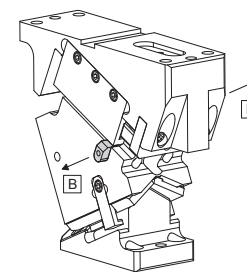

Slide out the spring stopper [B]

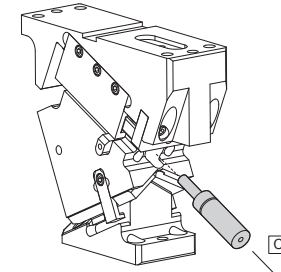

Remove the gas spring backward [C]

■ UCMSV165/200/250/300/350/400 Removing gas spring

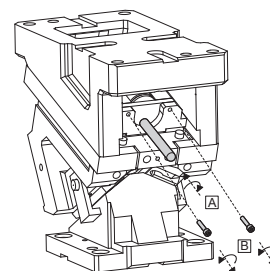

-Screw the mounting lever [A]
-Remove the screws of the spring stopper [B]

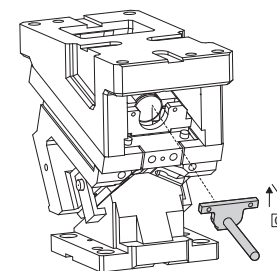

Slide out the spring stopper [C]

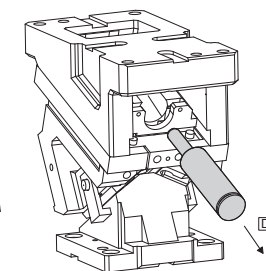

Remove the gas spring backward [D]

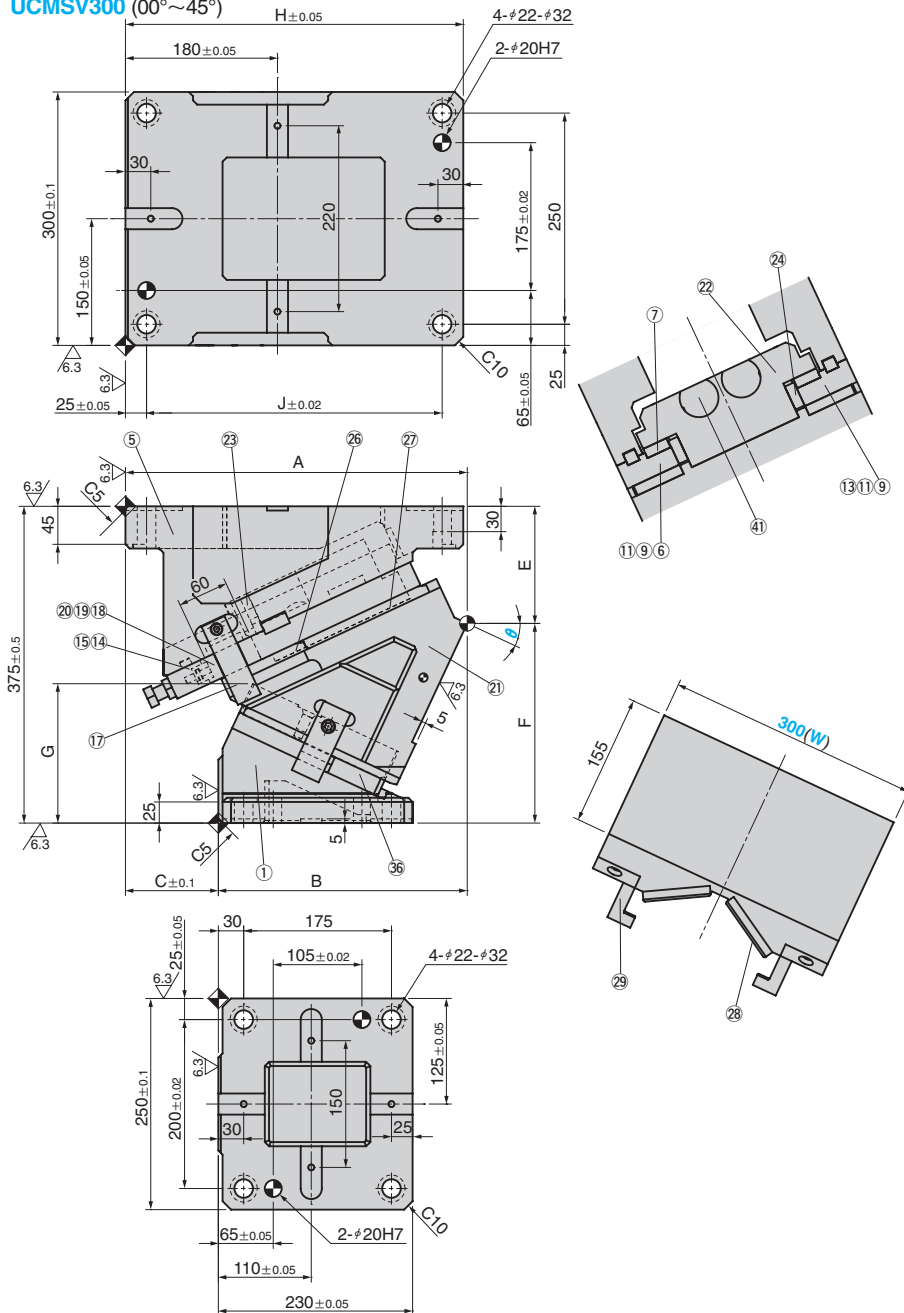
UCMSV300 (00°~45°)

θ	Travel	A	B	C	E	F	G	H	J
00	38.6	395.00	232.00	163	98.00	277.00	105.0		
05	42.6	387.15	232.15	155	104.19	270.81	116.9		
10	46.7	394.13	249.13	145	111.86	263.14	128.5	390	340
15	50.9	395.82	260.82	135	121.01	253.99	139.6		
20	55.3	397.08	277.08	120	131.59	243.41	150.2		
25	60	404.71	294.71	110	138.65	236.35	165.0		
30	65.1	408.22	323.22	85	146.89	228.11	179.2		
35	70.8	404.52	334.52	70	159.17	215.83	189.6	400	350
40	77.1	400.46	345.46	55	167.30	207.70	204.5		
45	84.5	394.84	354.84	40	179.24	195.76	215.6		

Working Force kN	Return Force N(kgf)	Catalog No.	(W)	θ	Spring Type PS
	29608 (3021.2)			00	
	29543 (3014.6)			05	
	29475 (3007.6)			10	
	29402 (3000.2)			15	GS
364	29327 (2992.6)	UCMSV	300	20	GK
	29250 (2984.7)			25	GD
	29170 (2976.5)			30	*NGP
	29089 (2968.3)			35	
	29007 (2959.9)			40	
	28925 (2951.5)			45	

Mark * Without gas spring but accessories for installation of each type are included.

Order **Catalog No.** **(W)** - **θ** - **PS**
UCMSV 300 - 25 - GK

Spring Specification (Qty 2)

Spring Type PS	θ	Spring Force N(kgf)		Model
		Initial Force	Final Force	
GK			21550 (2199.0)	X750-080-TD (KALLER)
GD	00~45	-	20700 (2112.2)	U.0800.080.TO (DADCO)
GS			21975 (2242.3)	SFC.750.80 (SDT)



Code	Specification
K	Dedicated key is attached. (It is not assembled to the main unit)
NF	Nitrogen gas is not charged. Applicable to GK, GS and GD only.

Order **UCMSV300 - 25 - GK - NF**

Key Specification

- Parts list is shown in p.1695
- Cam diagram is shown in p.1693
- NF : Gas Springs are not filled with nitrogen gas if delivery is by air freight.

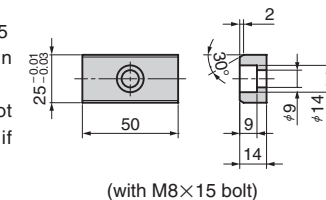

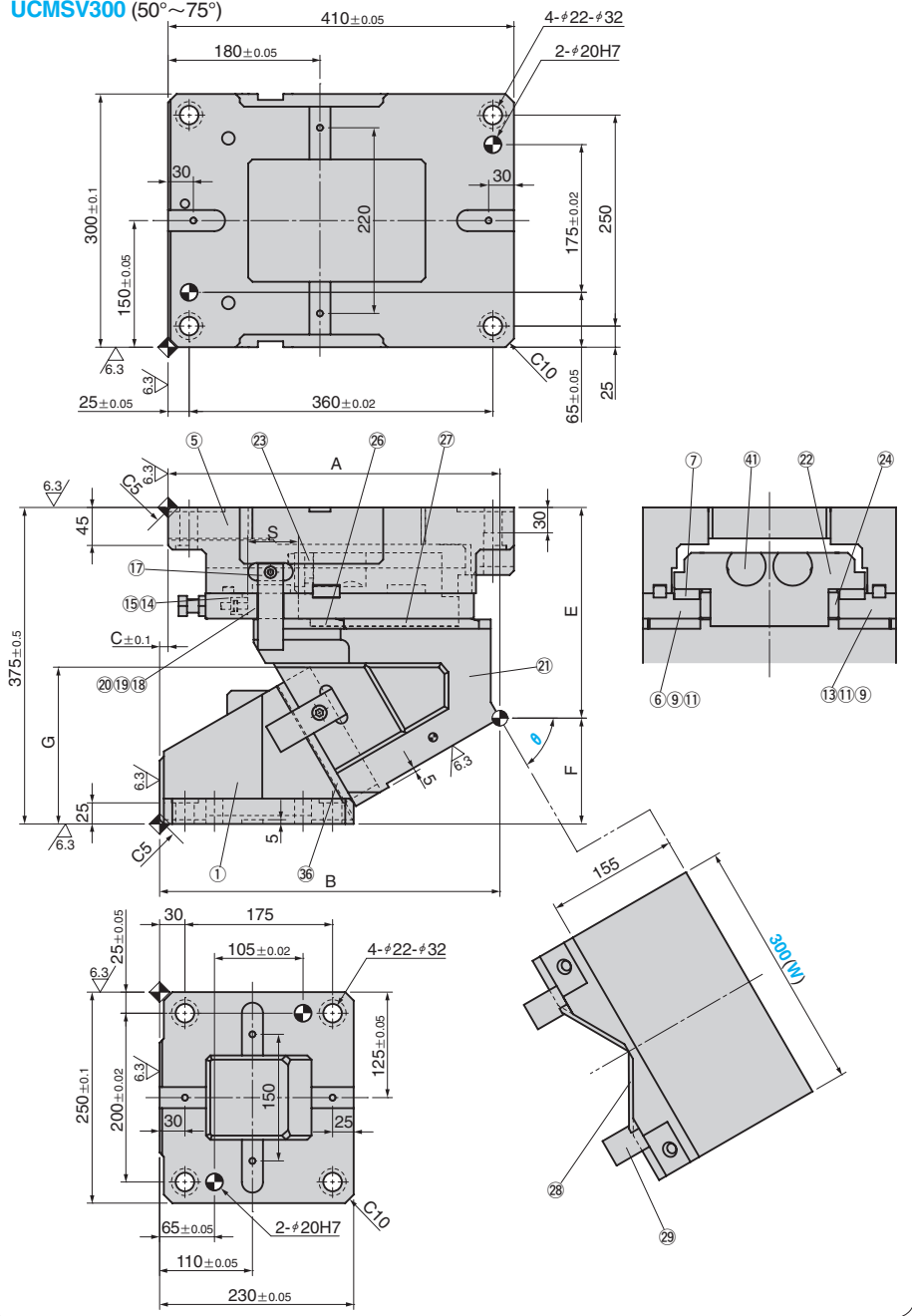
UCMSV300 (50°~75°)

θ	Travel	A	B	C	E	F	G	S
50	93.3	393.35	376.35	17	196.04	178.96	194.8	
55	104.6	393.35	393.35	0	222.75	152.25	188.8	60
60	120.0	393.35	403.35	-10	249.61	125.39	182.3	
65	94.6	387.48	415.48	-28	266.49	108.51	185.4	40
70	73.1	378.65	423.65	-45	281.99	93.01	189.2	
75	96.6	364.72	429.72	-65	296.88	78.12	193.0	25

Working Force kN	Return Force N(kgf)	Catalog No.	(W)	θ	Spring Type PS	
364	28842 (2943.1)	UCMSV	300	50	*NGP	
	31364 (3200.4)			55		GS
	34665 (3537.2)			60		GK
	37172 (3793.0)			65		GD
	40388 (4121.2)			70		
	48308 (4929.4)			75		

Mark * Without gas spring but accessories for installation of each type are included.

Order **Catalog No.** (W) - θ - PS
UCMSV 300 - 60 - GK

Spring Specification (Qty 2)

Spring Type PS	θ	Spring Force N(kgf)		Model
		Initial Force	Final Force	
GK	50~60	-	21550 (2199.0)	X750-080-TD (KALLER)
GD			20700 (2112.2)	U.0800.080.TO (DADCO)
GS			21975 (2242.3)	SFC.750.80 (SDT)
GK	65	-	20387 (2080.3)	X750-063-TD (KALLER)
GD			22720 (2318.4)	U.0800.063.TO (DADCO)
GS			20905 (2133.2)	SFC.750.63 (SDT)
GK	70~75	-	19200 (1959.2)	X750-050-TD (KALLER)
GD			18680 (1906.1)	U.0800.050.TO (DADCO)
GS			19650 (2005.1)	SFC.750.50 (SDT)

Option

Code	Specification
K	Dedicated key is attached. (It is not assembled to the main unit)
NF	Nitrogen gas is not charged. Applicable to GK, GS and GD only.

- Parts list is shown in p.1695
- Cam diagram is shown in p.1693
- NF : Gas Springs are not filled with nitrogen gas if delivery is by air freight.

Order **UCMSV300 - 60 - GK - NF**

Key Specification

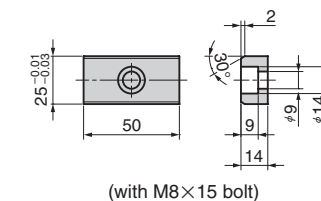

(with M8×15 bolt)

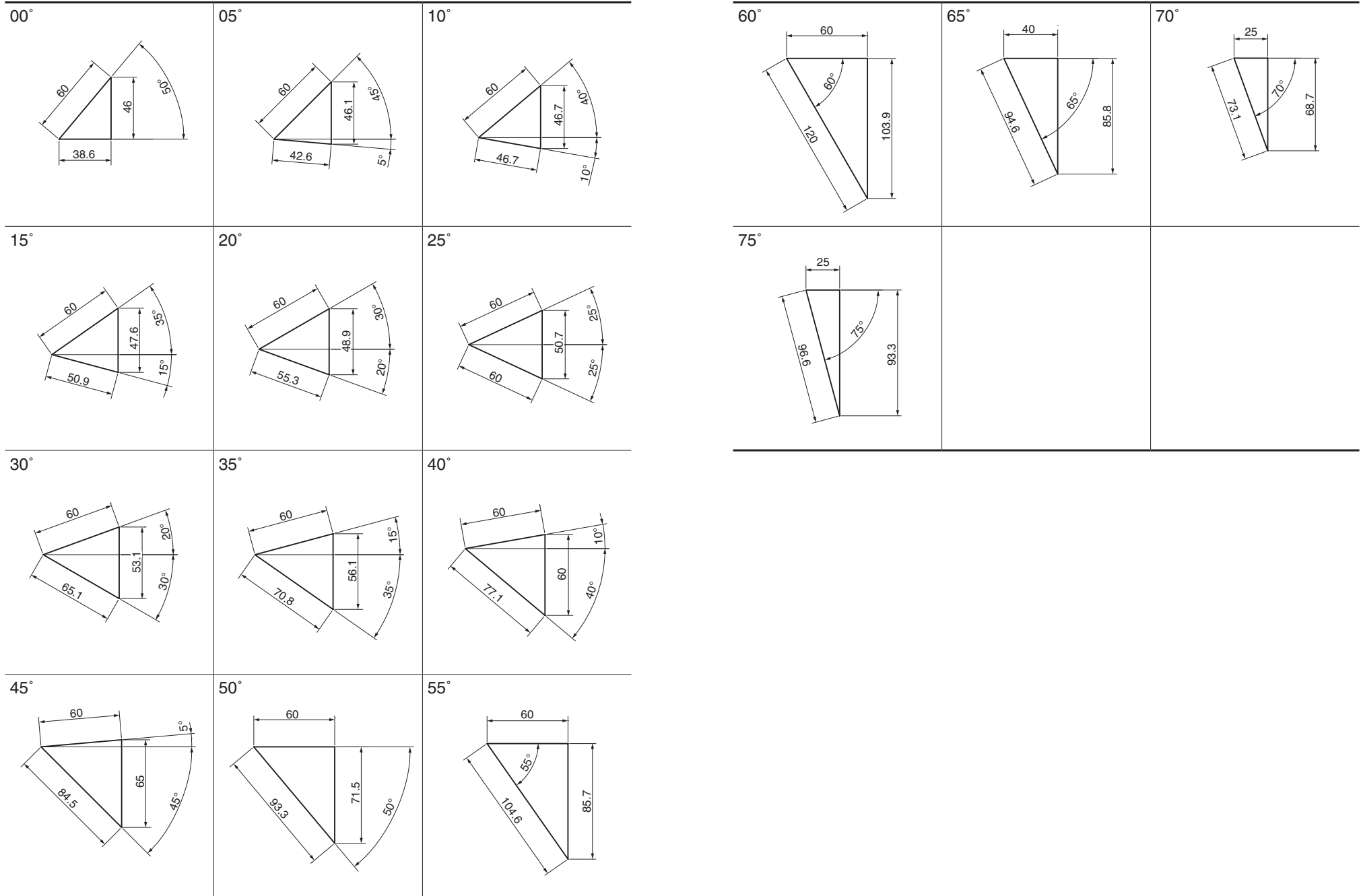

■ $\theta = 00^\circ \sim 50^\circ$

No.	Description	Qty	Material and Remark
①	Cam Driver	1	GGG60
⑤	Cam Holder	1	GGG60
⑥	Base Plate R	1	S45C
⑦	Slide Plate(VSM-15)	2	Bronze with Graphite
⑨	Key	4	SS400
⑪	Key	2	SS400
⑬	Base Plate L	1	S45C
⑭	Stopper plate	1	S45C
⑮	Stopper	4	Urethane(PCU20)
⑰	Safety Plate	2	S45C
⑱	Lock Block	1	SS400
⑲	Hexagonal Bolt	1	SCM435 M16×150
⑳	Hexagonal Nut	1	SCM435 M16
㉑	Cam Slider	1	GGG60
㉒	Spring Guide	1	S45C
㉓	Gas Spring Guide Plate	1	S45C
㉔	Slide Plate(VSM-14)	2	Bronze with Graphite
㉖	Slide Plate(VSM-26)	2	Bronze with Graphite
㉗	Slide Plate(VSM-29)	2	Bronze with Graphite
㉘	Slide Plate(VSM-35)	2	Bronze with Graphite
㉙	Positive Return Plate	2	S45C
㉚	Cam Slide Guide(Lower)	1	S45C
㉜	Gas Spring	2	Refer to the specification table

Bolts for assembly are not indicated.

■ $\theta = 55^\circ \sim 75^\circ$

No.	Description	Qty	Material and Remark
①	Cam Driver	1	GGG60
⑤	Cam Holder	1	GGG60
⑥	Base Plate R	1	S45C
⑦	Slide Plate(VSM-15)	2	Bronze with Graphite
⑨	Key	4	SS400
⑪	Key	2	SS400
⑬	Base Plate L	1	S45C
⑭	Stopper plate	1	S45C
⑮	Stopper	4	Urethane(PCU20)
⑰	Safety Plate	2	S45C
⑱	Lock Block	1	SS400
⑲	Hexagonal Bolt	1	SCM435 M16×150
⑳	Hexagonal Nut	1	SCM435 M16
㉑	Cam Slider	1	GGG60
㉒	Spring Guide	1	S45C
㉓	Gas Spring Guide Plate	1	S45C
㉔	Slide Plate(VSM-14)	2	Bronze with Graphite
㉖	Slide Plate(VSM-26)	2	Bronze with Graphite
㉗	Slide Plate(VSM-29)	2	Bronze with Graphite
㉘	Slide Plate(VSM-34)	2	Bronze with Graphite
㉙	Positive Return Plate	2	S45C
㉚	Cam Slide Guide(Lower)	1	S45C
㉜	Gas Spring	2	Refer to the specification table

Bolts for assembly are not indicated.