

Oilless Washer

Copper Alloy
Washer Type
SO#50SP2



SOBW



SOBWN (Type without Bolt Holes)

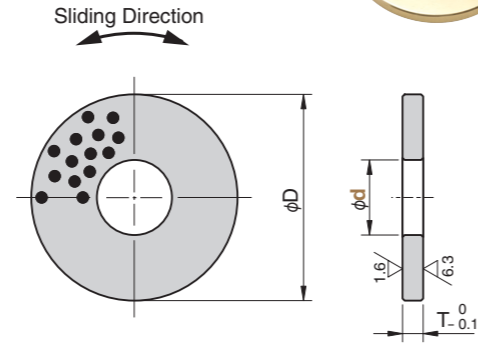
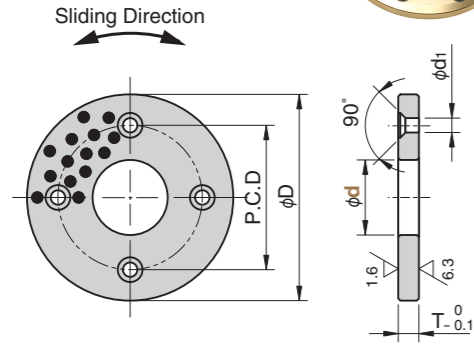
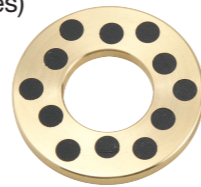

⚠ When the product is used at high temperature (150°C or more), the embedding specification of solid lubricant is different. Please contact us for details.

Material Base Copper alloy (SO-2)
Solid lubricant (GR-1)

Operation Range

Lubricant Type	Lubricating Condition	Environment Condition	Max. Allowable Load P N/mm ²	Max. Allowable Sliding Speed V m/min	Max. Allowable PV value N/mm ² · m/min	Operation Range Temperature °C
GR-1	No lubrication	Atmosphere	100	15	150	-50 ~ +300
	Regular lubrication (Grease)			30		

Physical Properties

Specific Gravity	Hardness HB	Elongation %	Tensile Strength N/mm ²	Linear Expansion Coefficient ×10 ⁻⁵ /°C
7.9	210 or more	12 or more	755 or more	1.9

d (Actual Size)	D	T	Bolt Mounting Hole			Catalog No.	d (Nominal)
			P.C.D	Quantity	Flat Head Screw		
10.2	30		20				10
12.2							12
13.2	40		28				13
14.2		3			M3	3.5	14
15.2							15
16.2	50		35				16
18.2				2			18
20.2							20
25.2	55		40				25
30.2	60	5	45		M5	6	30
35.2	70		50				35
40.2	80		60				40
45.3	90	7	67.5				45
50.3	100		75		M6	7	50
55.3	110		85				55
60.3	120	8	90				60
65.3	125		95				65
70.3	130		100				70
75.3	140		110	4	M8	9	75
80.3	150		120				80
90.5	170	10	140				90
100.5	190		160		M10	11	100
120.5	200		175				120

Type without Bolt Hole

d (Actual Size)	D	T	Catalog No.	d (Nominal)
10.2	30			10
12.2	40	3		12
16.2	50		SOBWN	16
20.2				20
25.2	55	5		25
30.2	60			30

Order	Catalog No.	d (Nominal)
	SOBW	18
	SOBWN	16