

Oilless Spherical Bush

Copper Alloy
Spherical Type
SO#50SP2

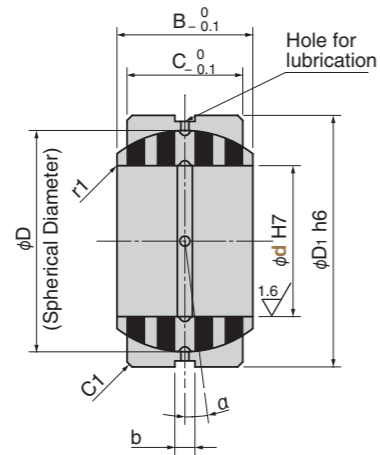

SOBS



Assembly type of spherical bushing

SOBS015~090(Side insertion type)

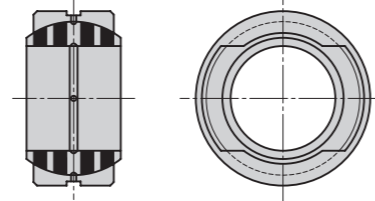

SOBS 100~(Split Bushing)

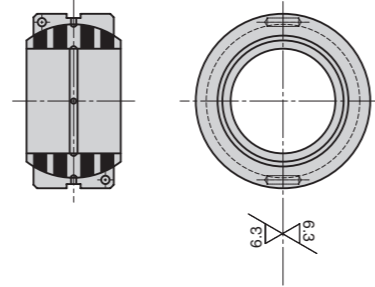

* Bushing can be used without lubrication and it may be lubricated on a regular basis from the lubrication hole.

Mating post tolerance

d8 : General use (high load)
e7 : General use (light load)

Housing hole tolerance

N7 : General use (high load)
H7 : General use (light load)

Other operating conditions and characteristics

Can be used in the atmosphere.
Good performance in operation under high load and at low speed.

⚠ When the product is used at high temperature (150°C or more), the embedding specification of solid lubricant is different. Please contact us for details.

Material Inner Ring Copper alloy (SO-2)
Solid lubricant (GR-1)
Outer Ring S45C Tempered
Non-electrolytic nickel plating

d H7	D1 h6	B	C	D	b	Alignment Angle α°	* Allowable Radial Load Rd (kN)	* Allowable Thrust Load Td (kN)	* Allowable Rdv Value kN · m/min	Catalog No.	Nominal	
15	+0.018 0	26	0 -0.013	12	9	22	8	6.5	0.5	6.5		015
20		32		16	14	28	4	12.6	1.4	12.6		020
25	+0.021 0	42	0 -0.016	21	18	36	5	21.8	2.5	21.8		025
30		50		27	23	44	6	32.0	3.5	32.0		030
35		55		30	26	49	5	43.7	4.8	43.7		035
40	+0.025 0	62	0 -0.019	33	28	55	4	54.7	5.7	54.7		040
45		72		36	31	62	5	69.7	7.2	69.7		045
50		80		42	36	70		92.4	10	92.4		050
60		100	0	53	45	90	6	143	16	143		060
70	+0.030 0	110	0 -0.022	58	50	99	5	181	20	181		070
80		130		70	60	115		254	30	254		080
90		140	0	76	65	125	6	313	36	313		090
100	+0.035 0	160	0 -0.025	88	75	145		544	64	544	SOBS	100
110		170		93	80	155	5	642	73	642		110
120		190		105	90	170	6	797	94	797		120
130		200		110	95	180	5	880	105	880		130
140		210	0 -0.029	90	70	180	6	668	56	668		140
150	+0.040 0	220		120	105	200	5	1135	129	1135		150
160		230		105	80	200	8	891	73	891		160
180		260	0 -0.032	105	80	225	6	1002	74	1002		180
200		290		130	100	250	7	1434	117	1434		200
220	+0.046 0	320		135	100	275	8	1577	118	1577		220
240		340	0	140	100	300		1720	118	1720		240
260		370	0 -0.036	150	110	325	9	2072	143	2072		260
280	+0.052 0	400		155	120	350	6	2455	172	2455		280
300		430	0 -0.040	165	120	375	7	2630	172	2630		300

⚠ When the bushing is used under water, it is recommended to select GR-9 for the solid lubricant of the inner ring, and stainless steel (SUS304) for the outer ring. Load in this case (*) is 50% of the values in the table above.

Order **Catalog No.** SOBS **Nominal** 100

⚠ Nominal=060 or more is production on request

For use (fixing method)

Regular lubrication with grease nipple can improve wear resistance

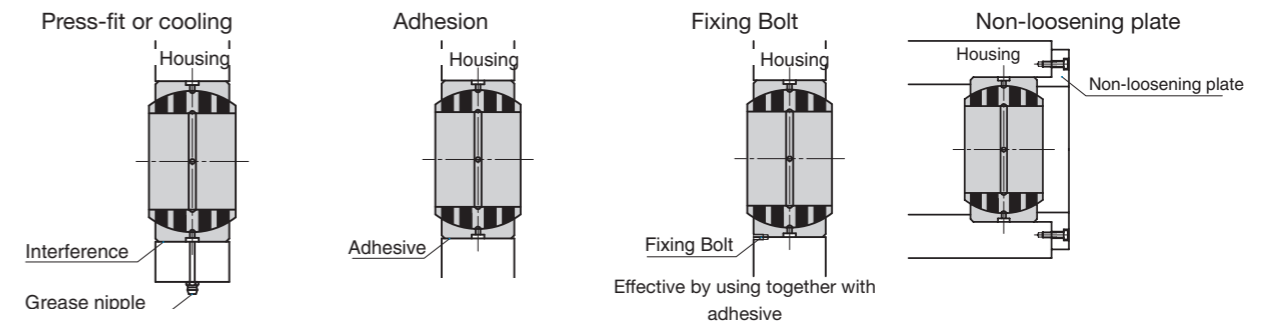

■ We are ready to accept requests or orders for special parts.

Operation Range

Lubricant Type	Lubricating Condition	Environment Condition	Max. Allowable Load P N/mm ²	Max. Allowable Sliding Speed V m/min	Max. Allowable PV value N/mm ² · m/min	Operation Range Temperature °C
GR-1	No lubrication	Atmosphere	100	15	150	-50 ~ +300
	Regular lubrication (Grease)			30	200	-50 ~ +150

Physical Properties

Specific Gravity	Hardness HB	Elongation %	Tensile Strength N/mm ²	Linear Expansion Coefficient ×10 ⁻⁵ /°C
7.9	210 or more	12 or more	755 or more	1.9

For use (fixing direction)

Side insertion Type

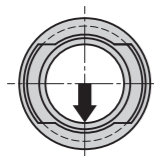

Install the bushing so that the loading direction may be perpendicular to the spherical insertion groove.

Split bushing Type

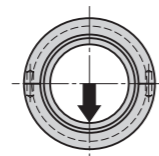

Install the bushing so that the loading direction may be perpendicular to the split surface.