

Die Mounted Cam Unit SKCA

Die Mounted Cam Unit

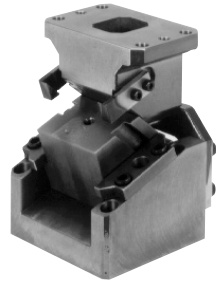

- Mounting surface widths 52, 65, 100, 150, 200, 200, 250, 300 mm
- Working angles from 0° to 20° in 5° increments for the mounting surface widths 65 to 150 mm
- The Box-type holder provides high rigidity

⚠ Gas Spring:

Please contact your local sales representative, if you prefer to use a gas spring not specified in our catalog. For use and maintenance of gas spring, please contact the manufacturer directly.

■ SKCA Assembly/ Dis-assembly

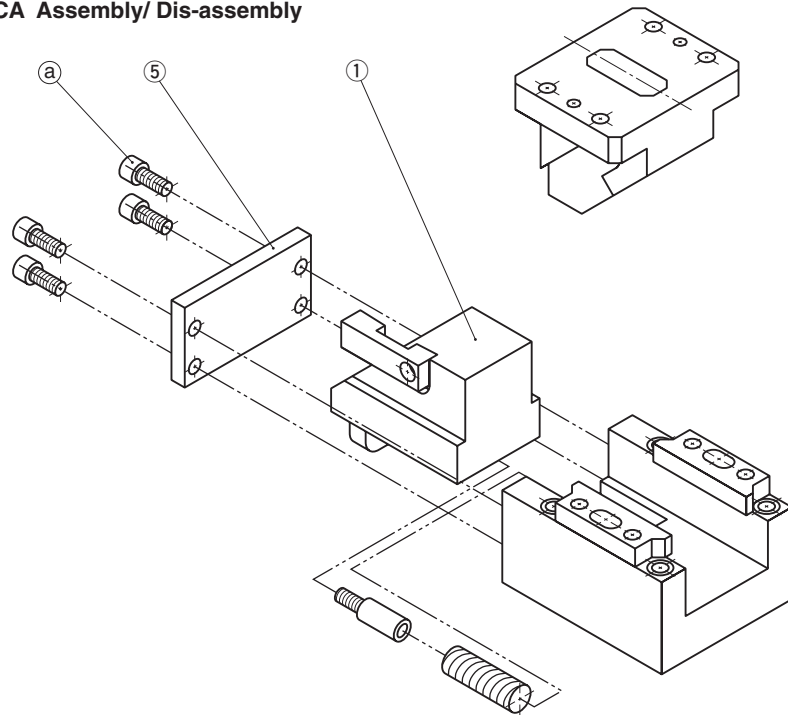

Coil Spring Specification

Technical Information

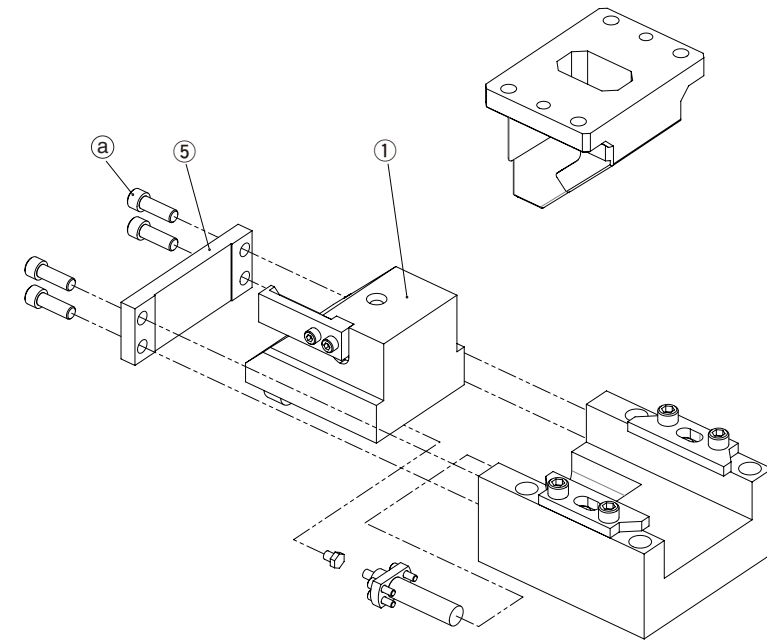

Gas Spring Specification

● Disassembling SKCA

- 1) Remove Hexagon Socket Head Bolts (a) and Stopper Plate (5).
- 2) Pull out Cam Slider from Cam Holder.

● Re-assembly

Reassembly is the reverse procedure of disassembly.

NOTES:

- Ensure that all parts are clean, particularly the sliding components, to which a small amount of grease is applied and is then placed in position.
- Take care that the respective tolerances are observed when assembling the Cam Slider and Cam Holder, which also should be identified by the same serial number.
- All bolts shall be tightened to the recommended torque after assembly and dis-assembly.

Die Mounted Cam Unit

FOR PIERCE AND FLANGE

Addition

CAD FILE

SKCA200 - 00 - 40

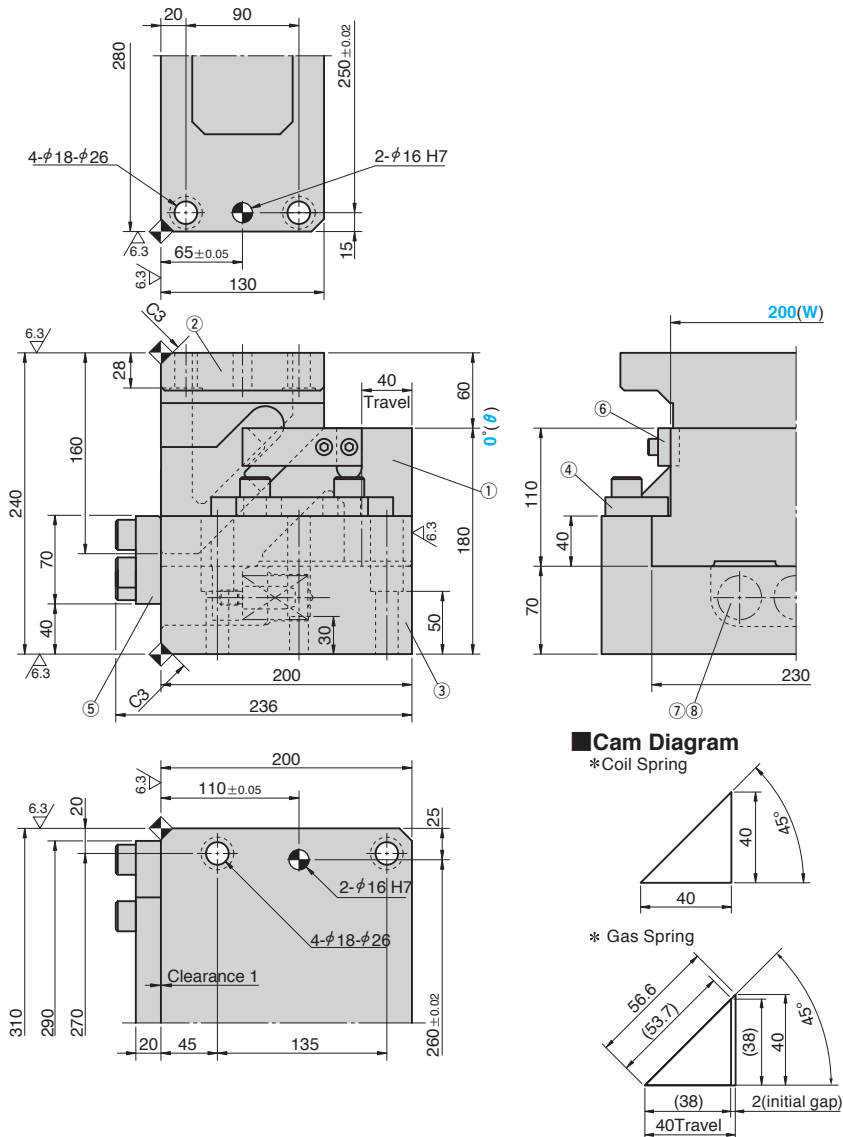

Cam Diagram

* Coil Spring

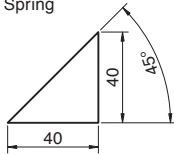

* Gas Spring

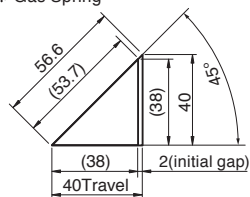

Working Force kN(tonf) 1,000,000 strokes	Spring Force N(kgf) 300,000 strokes	Initial Load		Final Load		Slider Weight kg	Total Weight kg	Catalog No.	W	θ	Travel S	Spring Type PS
		460.3 (47.0)	2761.9 (282.2)	2733 (278.9)								
78.4 (8.0)	117.6 (12.0)	-		21.0	82.0	SKCA	200	00	40	No code (Coil Spring)		
										GK	*NGK	
										GD	*NGD	
										GS	*NGS	

* Parts for spring assembly are included.



Order

Catalog No.	W	θ	S	PS	Option
SKCA	200	00	40	GK	
SKCA	200	00	40	NGK	
SKCA	200	00	40	GK	NF

...Without gas spring.



Option

Option Code	Specification
NF	Nitrogen gas not charged.

See page 389 for specifications of tapped and dowel pin holes for mounting a retainer.

Spring Specification

No.	PS	Spring Model	Qty	Remark
⑧	-	TF35-100	3	Coil Spring
	GK	M2-50-Yellow	1	Gas Spring (KALLER)
	GD	C.180.050.YW	1	Gas Spring (DADCO)
	GS	SFNA.200.50	1	Gas Spring (SDT)

*Gas filling pressure : 18MPa

Table of Components

No.	Description	Qty	Material and Remark
①	Cam Slider	1	FC250 with Graphite
②	Cam Driver	1	FC250 with Graphite
③	Cam Holder	1	FC250
④	Upper Plate	2	S45C Copper Powder Sintered
⑤	Stopper Plate	1	S50C
⑥	Positive Return Follower	2	S45C(1045)
⑦	Spring Guide Pin	3	φ18×60 Coil Spring specification only
⑧	Mounting Plate	1	Gas Spring specification only
⑧	Spring	-	Refer to the Spring Specification table.
⑪	Stop Pin	1	Gas Spring specification only

Spring Diagram

(Stripping Force at punch retraction of 5mm)

- Spring used TF35-100 (3 pieces)
- Spring constant 19.18N/mm (1.96kgf/mm)
- Spring life expectancy 300,000 strokes

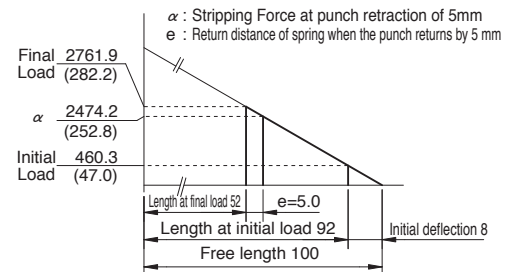

Bolts for assembly are not indicated.

Space for removing

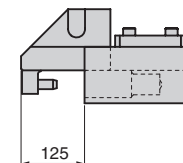

Die Mounted Cam Unit

FOR PIERCE AND FLANGE

CAD
FILE

SKCA200 - 00 - 60

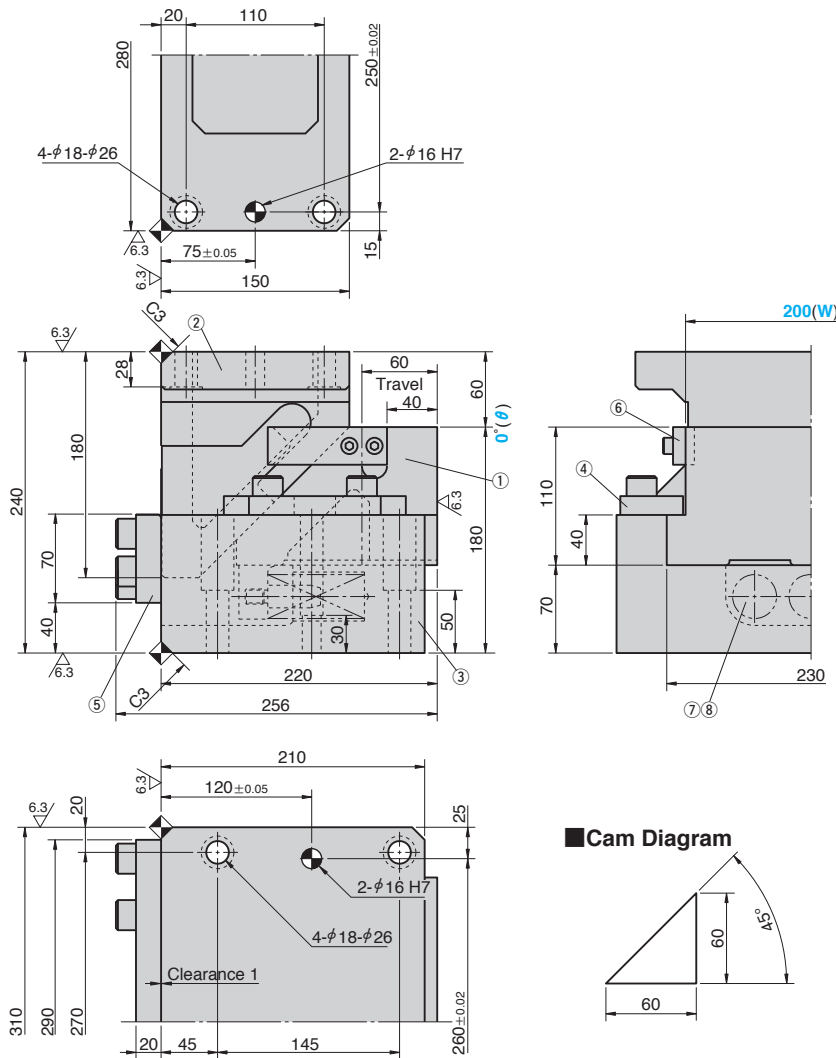

Cam Diagram

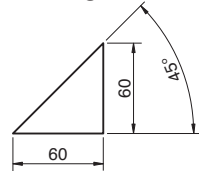

Working Force kN(tonf)		Spring Force N(kgf)		Slider Weight kg	Total Weight kg	Catalog No.	W	θ	Travel S
1,000,000 strokes	300,000 strokes	Initial Load	Final Load						
78.4 (8.0)	117.6 (12.0)	498.8 (50.7)	2801.0 (284.7)	21.0	84.0	SKCA	200	00	60

Order **Catalog No.** SKCA **W** 200 **θ** 00 **S** 60

Option See page 389 for specifications of tapped and dowel pin holes for mounting a retainer.

Table of Components

No.	Description	Qty	Material and Remark
①	Cam Slider	1	FC250 with Graphite
②	Cam Driver	1	FC250 with Graphite
③	Cam Holder	1	FC250
④	Upper Plate	2	S45C Copper Powder Sintered
⑤	Stopper Plate	1	S50C
⑥	Positive Return Follower	2	S45C(1045)
⑦	Spring Guide Pin	3	φ18×60
⑧	Coil Spring	3	TF35-150

⚠ Bolts for assembly are not indicated.

Spring Diagram

(Stripping Force at punch retraction of 5mm)

- Spring used TF35-150 (3 pieces)
- Spring constant 12.79N/mm (1.30kgf/mm)
- Spring life expectancy 300,000 strokes

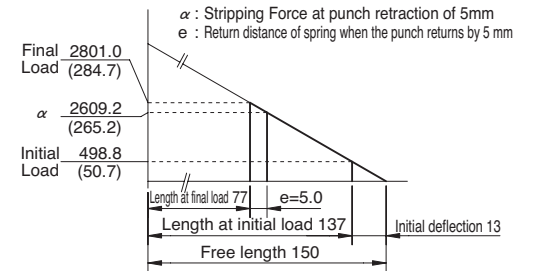

Space for removing

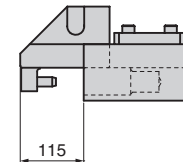

Die Mounted Cam Unit

FOR PIERCE AND FLANGE

CAD
FILE

SKCA250 - 00 - 40

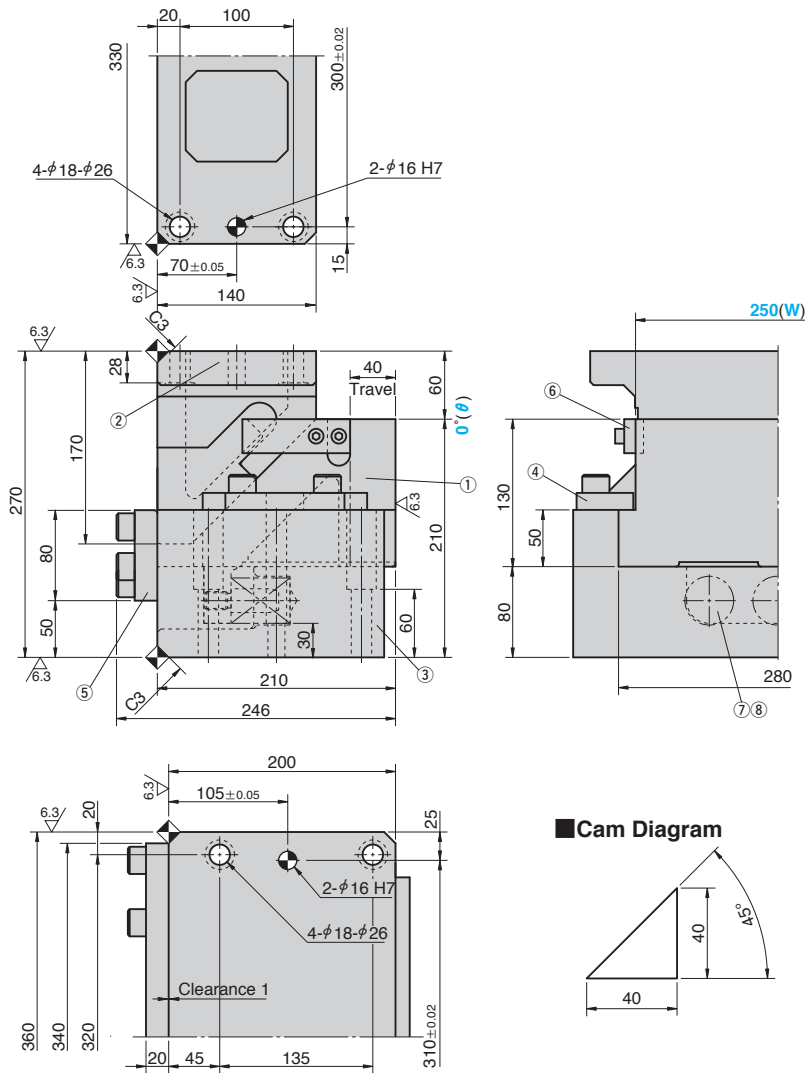

Working Force kN(tonf)	Spring Force N(kgf)		Slider Weight kg	Total Weight kg	Catalog No.	W	θ	Travel S	
	1,000,000 strokes	300,000 strokes							Initial Load
98.0 (10.0)	147.0 (15.0)	601.7 (61.4)	3610.1 (368.6)	33.4	97.0	SKCA	250	00	40

Order **Catalog No.** **W** - **θ** - **S**
SKCA 250 - 00 - 40

Option See page 389 for specifications of tapped and dowel pin holes for mounting a retainer.

Table of Components

No.	Description	Qty	Material and Remark
①	Cam Slider	1	FC250 with Graphite
②	Cam Driver	1	FC250 with Graphite
③	Cam Holder	1	FC250
④	Upper Plate	2	S45C Copper Powder Sintered
⑤	Stopper Plate	1	S50C
⑥	Positive Return Follower	2	S45C(1045)
⑦	Spring Guide Pin	3	φ21×65
⑧	Coil Spring	3	TF40-100

⚠ Bolts for assembly are not indicated.

Spring Diagram

(Stripping Force at punch retraction of 5mm)

- Spring used TF40-100 (3 pieces)
- Spring constant 25.07N/mm (2.56kgf/mm)
- Spring life expectancy 300,000 strokes

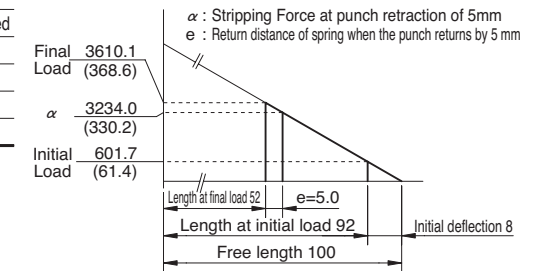

Space for removing

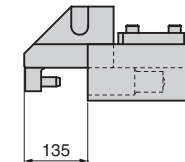

Cam Diagram

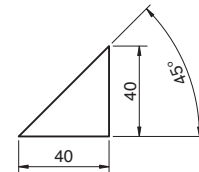

Die Mounted Cam Unit

FOR PIERCE AND FLANGE

CAD
FILE

SKCA250 - 00 - 60

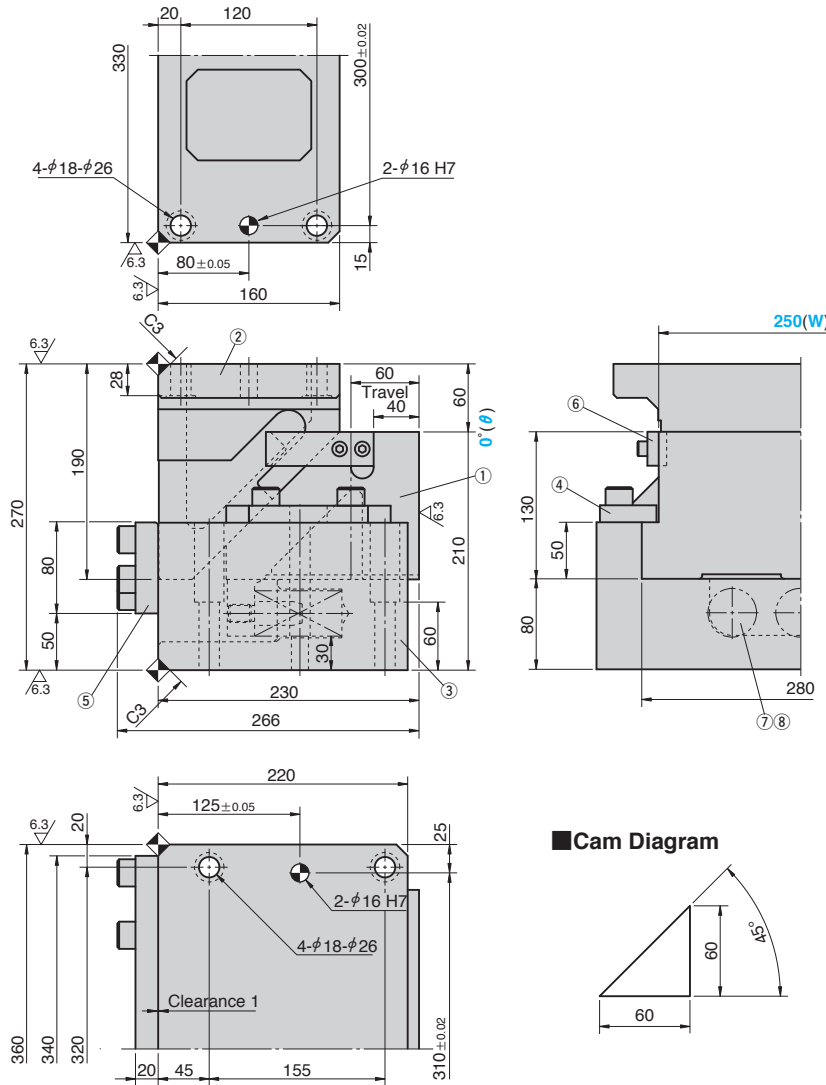

Working Force kN(tonf)		Spring Force N(kgf)		Slider Weight kg	Total Weight kg	Catalog No.	W	θ	Travel S
1,000,000 strokes	300,000 strokes	Initial Load	Final Load						
98.0 (10.0)	147.0 (15.0)	651.7 (66.3)	3659.4 (372.3)	33.4	105.3	SKCA	250	00	60

Order **Catalog No.** SKCA **W** 250 **θ** 00 **S** 60

Option See page 389 for specifications of tapped and dowel pin holes for mounting a retainer.

Table of Components

No.	Description	Qty	Material and Remark
①	Cam Slider	1	FC250 with Graphite
②	Cam Driver	1	FC250 with Graphite
③	Cam Holder	1	FC250
④	Upper Plate	2	S45C Copper Powder Sintered
⑤	Stopper Plate	1	S50C
⑥	Positive Return Follower	2	S45C(1045)
⑦	Spring Guide Pin	3	φ21×65
⑧	Coil Spring	3	TF40-150

⚠ Bolts for assembly are not indicated.

Spring Diagram

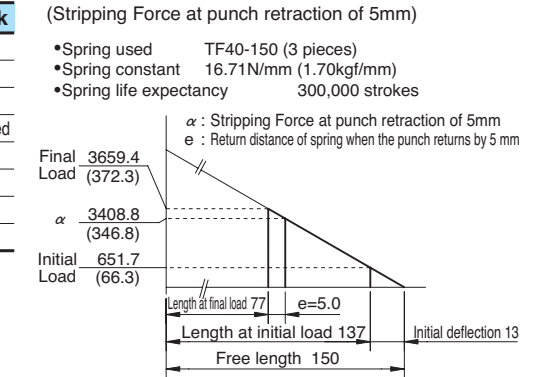

Space for removing

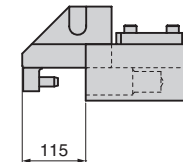

Cam Diagram

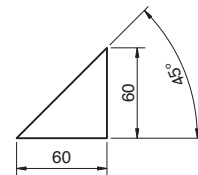

Die Mounted Cam Unit

FOR PIERCE AND FLANGE

CAD
FILE

SKCA300 - 00 - 40

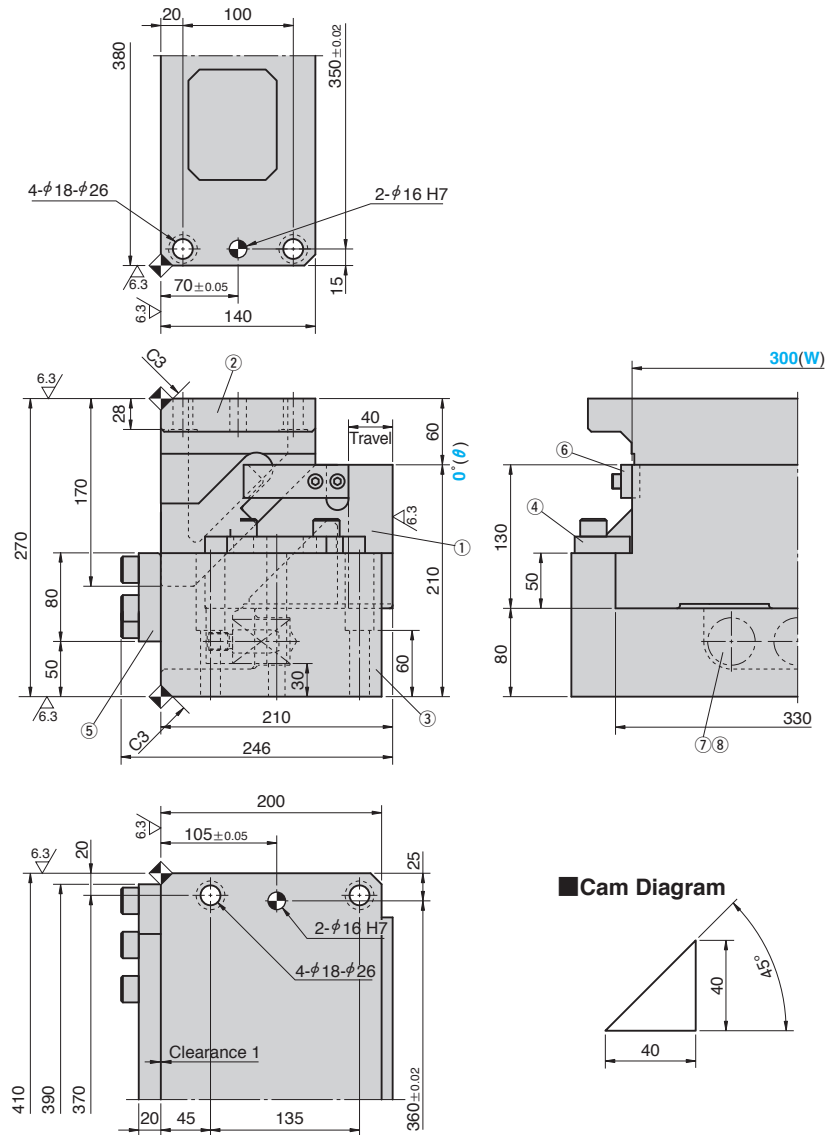

Working Force kN(tonf)		Spring Force N(kgf)		Slider Weight kg	Total Weight kg	Catalog No.	W	θ	Travel S
1,000,000 strokes	300,000 strokes	Initial Load	Final Load						
117.6 (12.0)	176.4 (18.0)	601.7 (61.4)	3610.1 (368.6)	38.0	113.1	SKCA	300	00	40

Order **Catalog No.** **W** - **θ** - **S**
SKCA 300 - 00 - 40

Option See page 389 for specifications of tapped and dowel pin holes for mounting a retainer.

Table of Components

No.	Description	Qty	Material and Remark
①	Cam Slider	1	FC250 with Graphite
②	Cam Driver	1	FC250 with Graphite
③	Cam Holder	1	FC250
④	Upper Plate	2	S45C Copper Powder Sintered
⑤	Stopper Plate	1	S50C
⑥	Positive Return Follower	2	S45C(1045)
⑦	Spring Guide Pin	3	φ21×65
⑧	Coil Spring	3	TF40-100

⚠ Bolts for assembly are not indicated.

Spring Diagram

(Stripping Force at punch retraction of 5mm)

- Spring used TF40-100 (3 pieces)
- Spring constant 25.07N/mm (2.56kgf/mm)
- Spring life expectancy 300,000 strokes

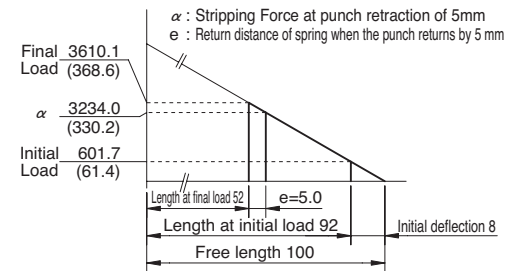

Space for removing

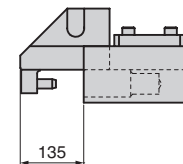

Cam Diagram

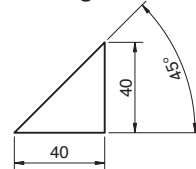

Die Mounted Cam Unit

FOR PIERCE AND FLANGE

CAD
FILE

SKCA300 - 00 - 60

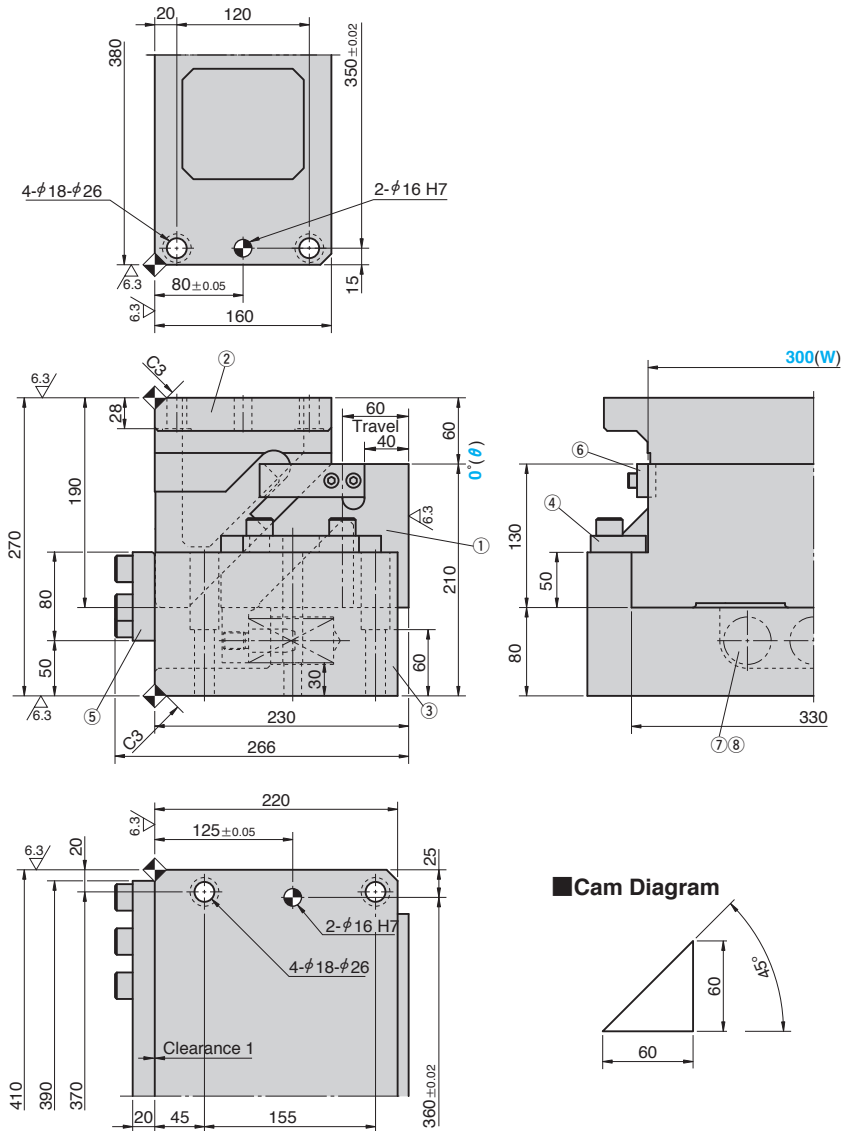

Working Force kN(tonf)		Spring Force N(kgf)		Slider Weight kg	Total Weight kg	Catalog No.	W	θ	Travel S
1,000,000 strokes	300,000 strokes	Initial Load	Final Load						
117.6 (12.0)	176.4 (18.0)	651.7 (66.3)	3659.4 (372.3)	38.0	120.4	SKCA	300	00	60

Order **Catalog No.** **W** - **θ** - **S**
SKCA 300 - 00 - 60

Option See page 389 for specifications of tapped and dowel pin holes for mounting a retainer.

Table of Components

No.	Description	Qty	Material and Remark
①	Cam Slider	1	FC250 with Graphite
②	Cam Driver	1	FC250 with Graphite
③	Cam Holder	1	FC250
④	Upper Plate	2	S45C Copper Powder Sintered
⑤	Stopper Plate	1	S50C
⑥	Positive Return Follower	2	S45C(1045)
⑦	Spring Guide Pin	3	φ21×65
⑧	Coil Spring	3	TF40-150

Bolts for assembly are not indicated.

Spring Diagram

(Stripping Force at punch retraction of 5mm)

- Spring used TF40-150 (3 pieces)
- Spring constant 16.71N/mm (1.70kgf/mm)
- Spring life expectancy 300,000 strokes

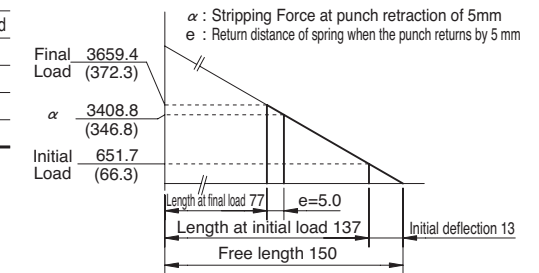

Space for removing

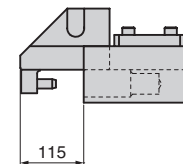

Cam Diagram

