

Die Mounted Cam Unit KCMSL

LARGE TYPE FOR PIERCE AND FLANGE

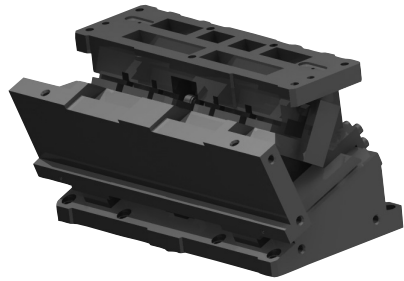

- The mounting surface widths are available in 100mm increments from 500 to 1000mm.
NOTE: 1600mm wide or smaller available on demand
- The working angles are available in 5° increments from 0° to 20°.
- Gas Spring is removable from the rear without disassembling.

⚠ Gas Spring:
Please contact your local sales representative if you prefer to use a gas spring not specified in our catalog. For use and maintenance of gas spring, please contact the manufacturer directly.

Specifications

Mounting Surface		Working Angle	Travel	Working Force kN(tonf)	Spring Force N(kgf)
W	H				
500 600	180	00	60	313.6 (32.0)	19600.0 (2000.0)
		05			
		10			
		15			
		20			
700 800	180	00	60	470.4 (48.0)	19600.0 (2000.0)
		05			
		10			
		15			
		20			
900 1000	180	00	60	627.2 (64.0)	39200.0 (4000.0)
		05			
		10			
		15			
		20			

Assembly · Disassembly

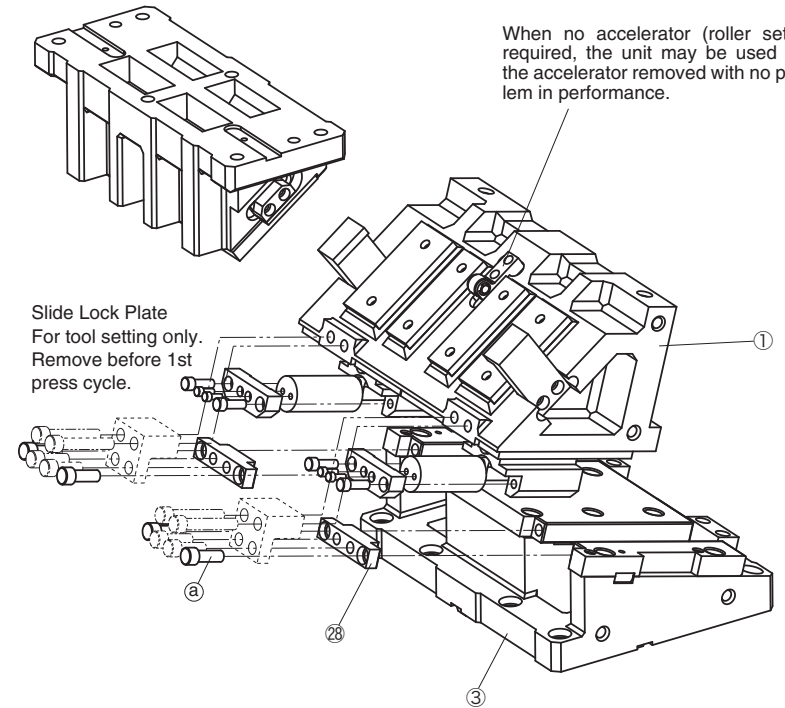

Disassembly method

- 1) Remove the Hexagon Socket Head Bolts (a) and the Stopper Plate (28).
- 2) Pull out Cam Slider (1) from Cam Holder (3).

Assembly method

Assemble parts in the reverse order of disassembly.

NOTE

- Make sure that there is no foreign matter on the sliding area and apply grease on sliding surface.
- Since clearances of 1 Cam Slider and 3 Cam Holder are controlled make sure that serial numbers engraved on the Cam Slider and the Cam Holder are identical.
- After assembly, make sure that all bolts are correctly tightened.

Die Mounted Cam Unit

LARGE TYPE FOR PIERCE AND FLANGE

CAD
FILE

KCMSL700-00 / KCMSL800-00

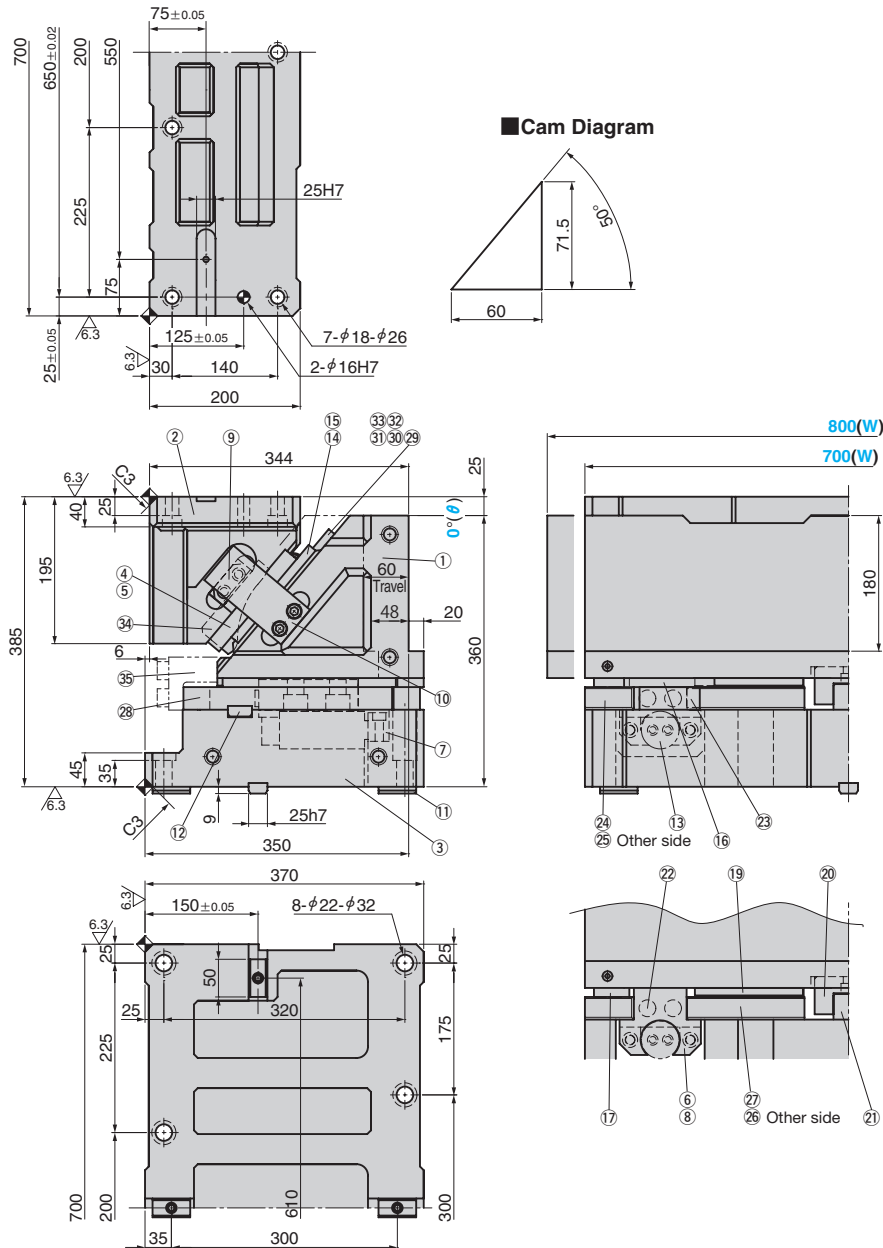

Cam Diagram

Travel S	Working Force kN(tonf)	Spring Force N(kgf)		Catalog No.	W	θ	Spring Type PS
		Initial Load	Final Load				
60.0	470.4 (48.0)	-	20200 (2060)	KCMSL	700 800	00	GK *NGK
		-	19600 (2000)				GD *NGD

No code: Coil spring
GK: Gas spring (KALLER)
GD: Gas spring (DADCO)
NGK/NGD: without gas spring
Parts for spring assembly are included.



Order

Catalog No.	W	θ	PS
KCMSL	700	00	GK
KCMSL	800	00	NGK



Option

Option Code	Specification
NF	Nitrogen gas not charged.



Order

KCMSL700-00-GK-NF

Spring Specification (Qty 2)

No.	PS	Spring Model
13	GK	K750-80 (KALLER)
	GD	L750.075.TO.140 (DADCO)

Weight(kg)

W	Slider Weight	Total Weight
700	197.0	436
800	205.4	446

Space for removing

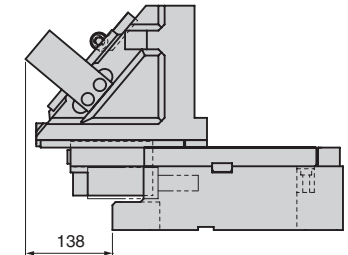

Refer to page 1175 for the table of components.

Die Mounted Cam Unit

LARGE TYPE FOR PIERCE AND FLANGE

CAD
FILE

KCMSL700-05 / KCMSL800-05

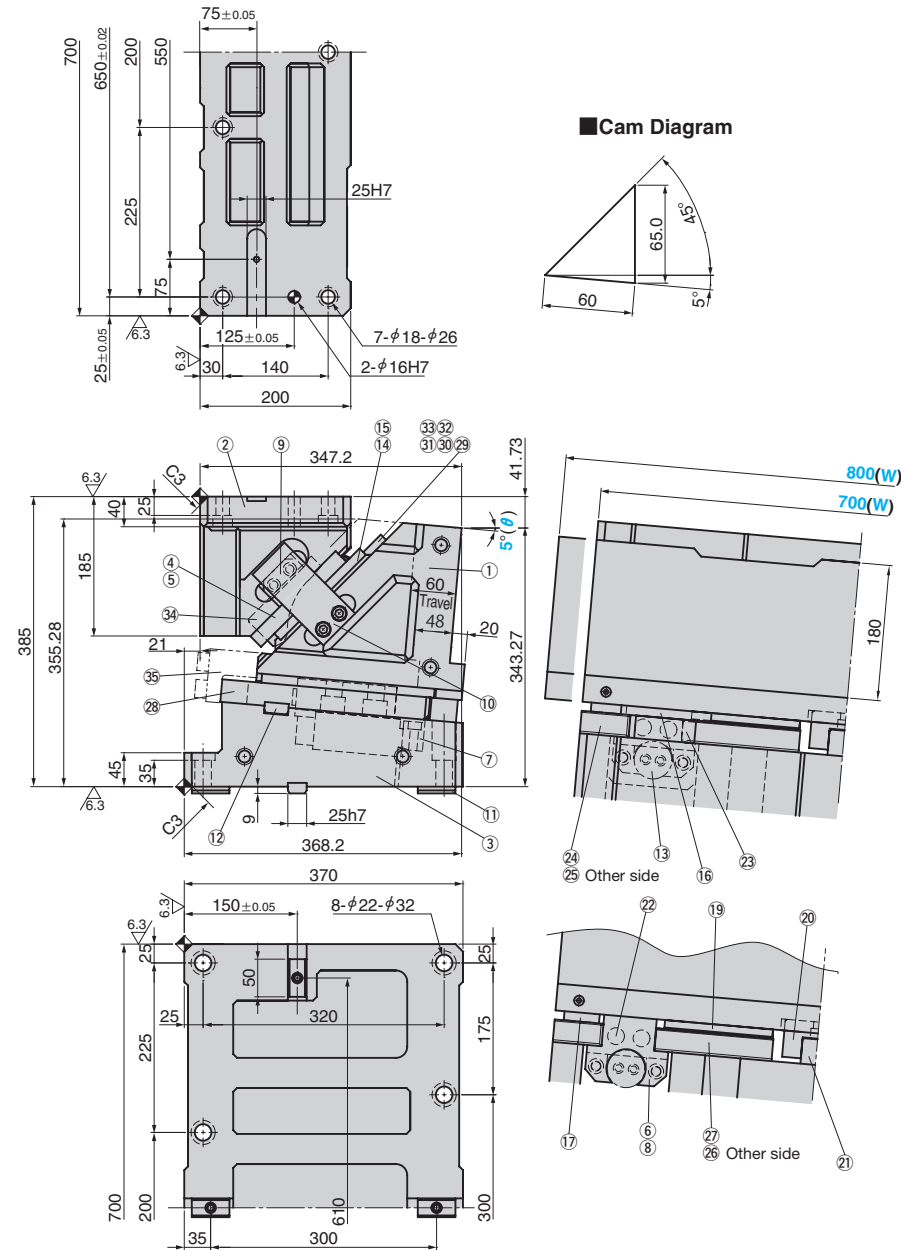

Cam Diagram

Travel S	Working Force kN(tonf)	Spring Force N(kgf)		Catalog No.	W	θ	Spring Type PS
		Initial Load	Final Load				
60.0	470.4 (48.0)	-	20200 (2060)	KCMSL	700 800	05	GK *NGK
		-	19600 (2000)				GD *NGD

No code: Coil spring
GK: Gas spring (KALLER)
GD: Gas spring (DADCO)
NGK/NGD: without gas spring
Parts for spring assembly are included.



Order

Catalog No.	W	θ	PS
KCMSL 700	700	05	GK
KCMSL 800	800	05	NGK



Option

Option Code	Specification
NF	Nitrogen gas not charged.



Order

KCMSL700-05-GK-NF

Spring Specification (Qty 2)

No.	PS	Spring Model
13	GK	K750-80 (KALLER)
	GD	L750.075.TO.140 (DADCO)

Weight(kg)

W	Slider Weight	Total Weight
700	197.0	429
800	205.4	438

Space for removing

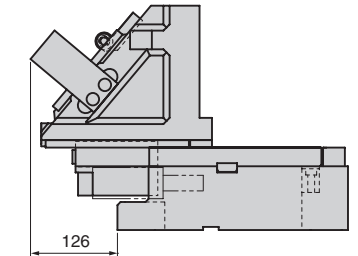

Refer to page 1175 for the table of components.

Die Mounted Cam Unit

LARGE TYPE FOR PIERCE AND FLANGE

CAD
FILE

KCMSL700-10 / KCMSL800-10

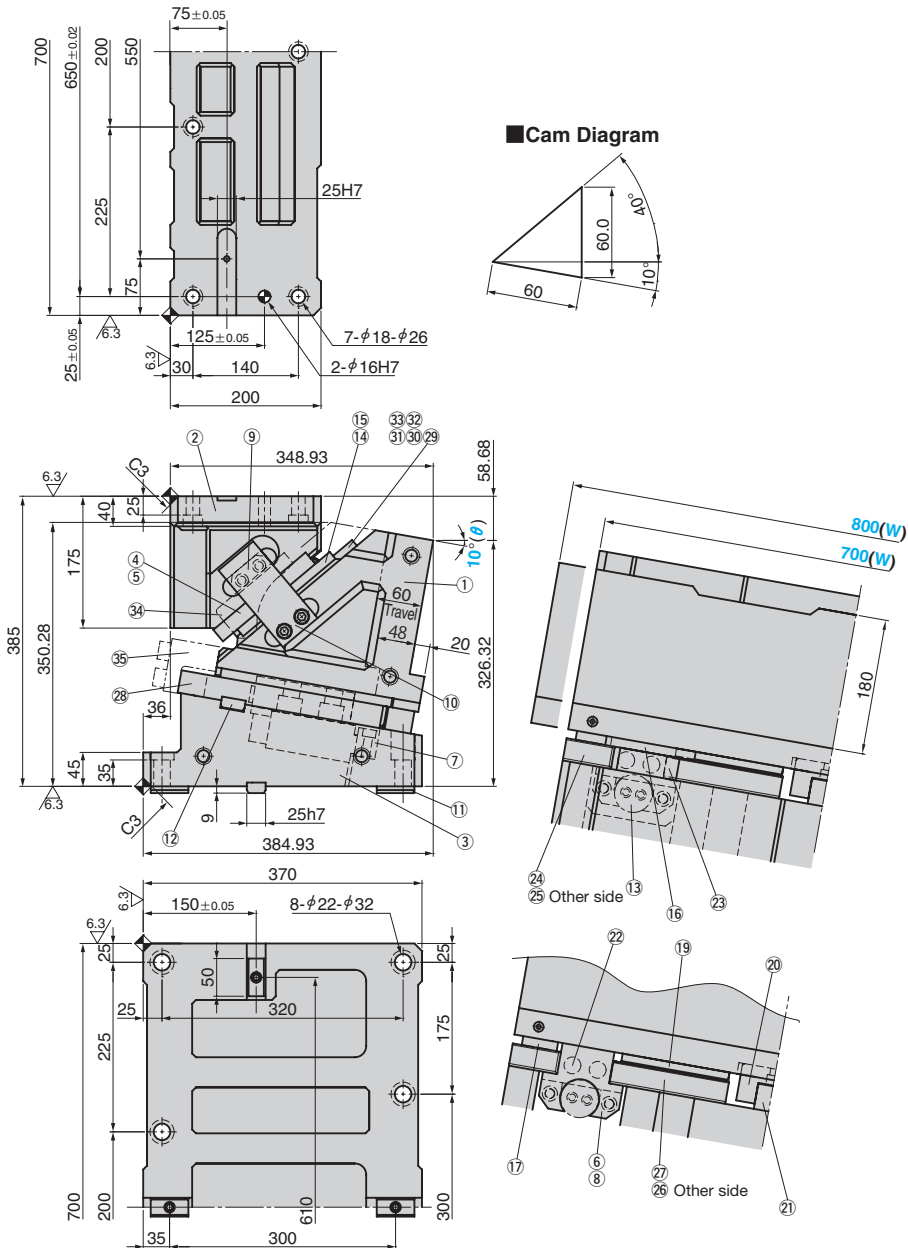

Cam Diagram

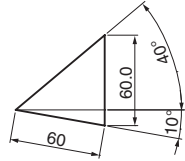

Travel S	Working Force kN(tonf)	Spring Force N(kgf)		Catalog No.	W	θ	Spring Type PS
		Initial Load	Final Load				
60.0	470.4 (48.0)	-	20200 (2060)	KCMSL	700 800	10	GK *NGK
		-	19600 (2000)				GD *NGD

No code: Coil spring
GK: Gas spring (KALLER)
GD: Gas spring (DADCO)
NGK/NGD: without gas spring
Parts for spring assembly are included.



Order

Catalog No.	W	θ	PS
KCMSL	700	10	GK
KCMSL	800	10	NGK



Option

Option Code	Specification
NF	Nitrogen gas not charged.



Order

KCMSL700-10-GK-NF

Spring Specification (Qty 2)

No.	PS	Spring Model
13	GK	K750-80 (KALLER)
	GD	L750.075.TO.140 (DADCO)

Weight(kg)

W	Slider Weight	Total Weight
700	197.0	421
800	205.4	430

Space for removing

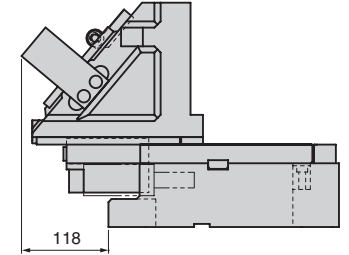

Refer to page 1175 for the table of components.

Cam Unit

Die Mounted Cam Unit

LARGE TYPE FOR PIERCE AND FLANGE

CAD
FILE

KCMSL700-15 / KCMSL800-15

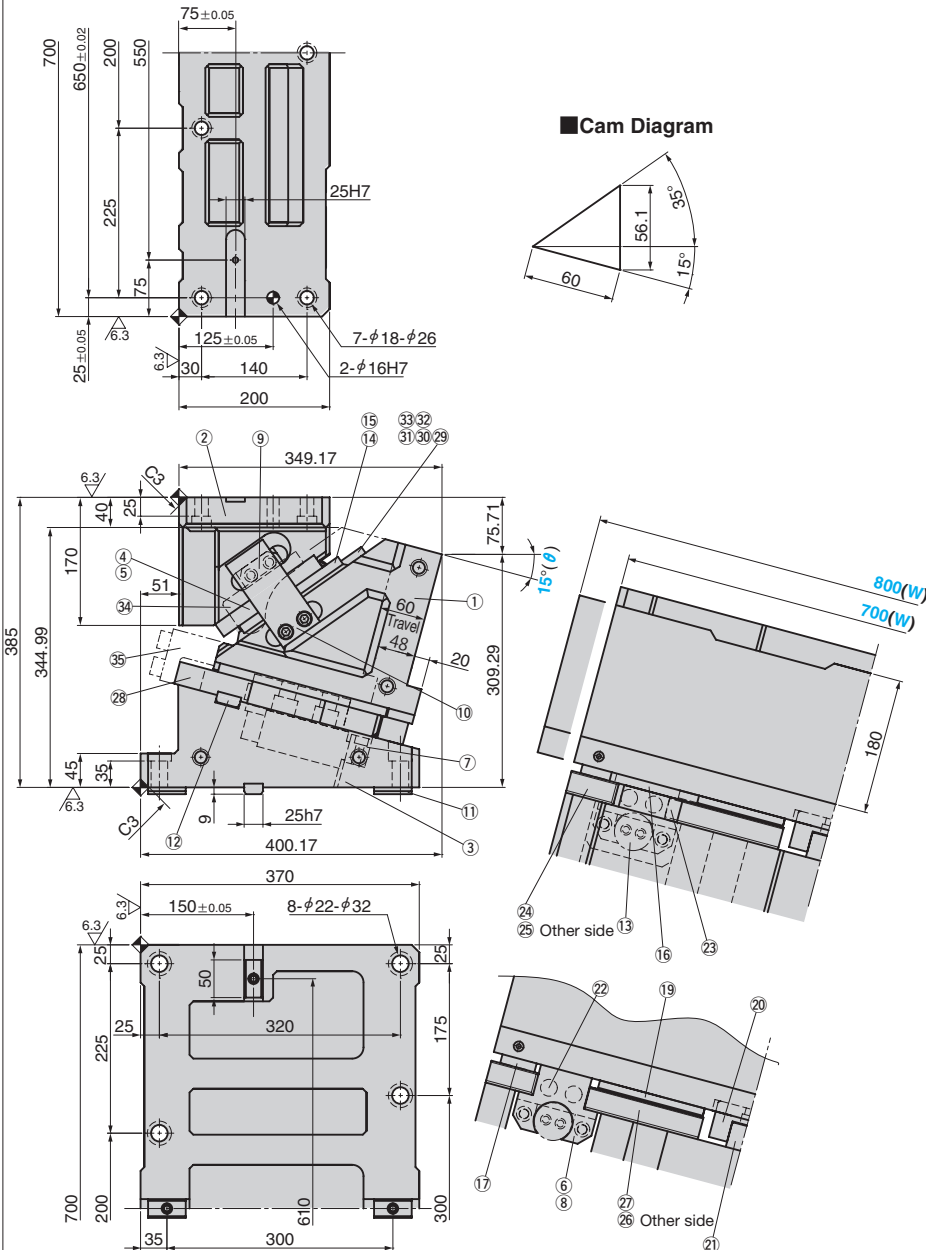

Travel S	Working Force kN(tonf)	Spring Force N(kgf)		Catalog No.	W	θ	Spring Type PS
		Initial Load	Final Load				
60.0	470.4 (48.0)	-	20200 (2060)	KCMSL	700 800	15	GK *NGK
		-	19600 (2000)				GD *NGD

No code: Coil spring
 GK: Gas spring (KALLER)
 GD: Gas spring (DADCO)
 NGK/NGD: without gas spring
 Parts for spring assembly are included.

Order

Catalog No.	W	θ	PS
KCMSL	700	15	GK
KCMSL	800	15	NGK

Option

Option Code	Specification
NF	Nitrogen gas not charged.

Order KCMSL700-15-GK-NF

Spring Specification (Qty 2)

No.	PS	Spring Model
13	GK	K750-80 (KALLER)
	GD	L750.075.TO.140 (DADCO)

Weight(kg)

W	Slider Weight	Total Weight
700	197.0	415
800	205.4	424

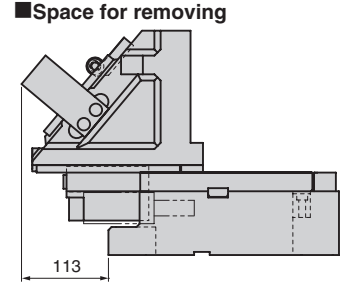

Refer to page 1175 for the table of components.

Die Mounted Cam Unit

LARGE TYPE FOR PIERCE AND FLANGE

CAD
FILE

KCMSL700-20 / KCMSL800-20

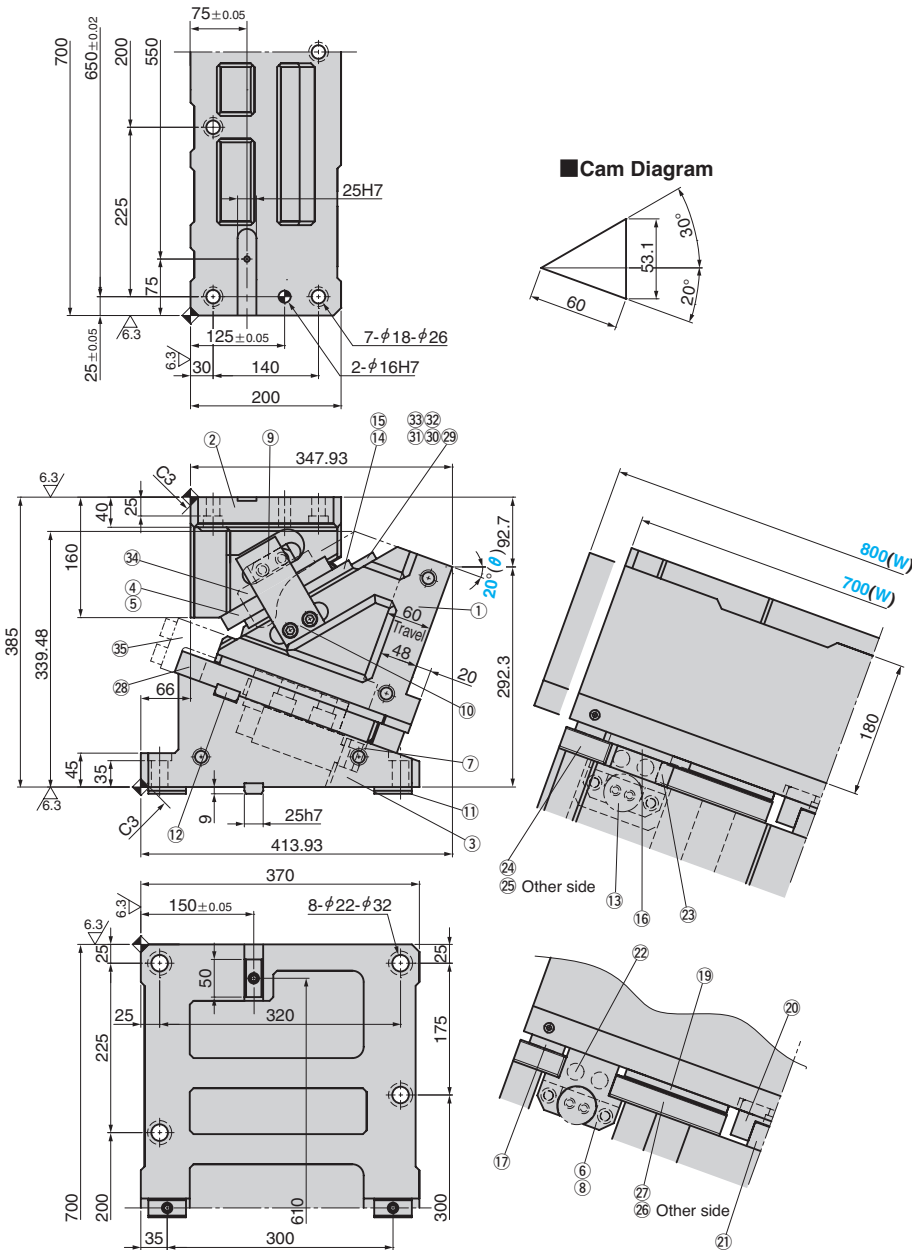

Cam Diagram

Travel S	Working Force kN(tonf)	Spring Force N(kgf)		Catalog No.	W	θ	Spring Type
		Initial Load	Final Load				PS
60.0	470.4 (48.0)	-	20200 (2060)	KCMSL	700 800	20	GK *NGK
		-	19600 (2000)				GD *NGD

No code: Coil spring
GK: Gas spring (KALLER)
GD: Gas spring (DADCO)
NGK/NGD: without gas spring
Parts for spring assembly are included.



Order

Catalog No.	W	θ	PS
KCMSL	700	20	GK
KCMSL	800	20	NGK



Option

Option Code	Specification
NF	Nitrogen gas not charged.



Order

KCMSL700-20-GK-NF

Spring Specification (Qty 2)

No.	PS	Spring Model
13	GK	K750-80 (KALLER)
	GD	L750.075.TO.140 (DADCO)

Weight(kg)

W	Slider Weight	Total Weight
700	197.0	410
800	205.4	418

Space for removing

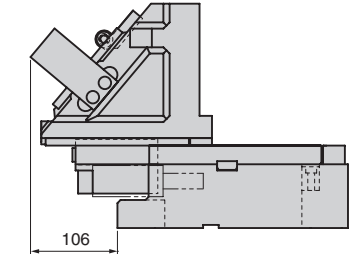

Refer to page 1175 for the table of components.

Die Mounted Cam Unit Table of Components KCMSL

LARGE TYPE FOR PIERCE AND FLANGE

■ Table of Components (KCMSL500/600)

No.	Description	Qty	Material and Remark
①	Cam Slider	1	FC250
②	Cam Driver	1	FC250
③	Cam Holder	1	FC250
④	Cam Driver Plate A	2	Bronze with Graphite
⑤	Cam Driver Plate B	2	Bronze with Graphite
⑥	Spring Guide	2	Bronze with Graphite
⑦	Guide Pin Block	2	Steel
⑧	Spring Guide Plate	2	Steel
⑨	Positive Return Block	2	Bronze with Graphite
⑩	Positive Return Follower	2	S45C (1045 Hardened)
⑪	Key A	4	Steel
⑫	Key B	4	Steel
⑬	Gas Spring	2	Refer to the spring type table.
⑭	Lower Plate A	2	S45C (1045 Hardened)
⑮	Lower Plate B	2	S45C (1045 Hardened)
⑯	Slide Lower Plate A	2	Bronze with Graphite
⑰	Slide Lower Plate B	4	Bronze with Graphite
⑳	Center Key Guide	1	S45C (1045 Hardened)
㉑	Center Key	1	Bronze with Graphite
㉒	Stopper	4	Urethane
㉓	Base Plate A	2	S45C (1045 Hardened)
㉔	Base Plate B- L	1	S45C (1045 Hardened)
㉕	Base Plate C- L	1	S45C (1045 Hardened)

No.	Description	Qty	Material and Remark
㉖	Base Plate B- R	1	S45C (1045 Hardened)
㉗	Base Plate C- R	1	S45C (1045 Hardened)
㉘	Stopper Plate	2	Steel
㉙	Roller Bracket	1	Steel
㉚	Roller	1	S45C (1045 Hardened)
㉛	Roller Pin	1	S45C (1045 Hardened)
㉜	Bushing	1	SOB12-18-16
㉝	E Type Snap Ring	2	φ9
㉞	Roller Driver	1	S45C (1045 Hardened)
㉟	Lock Plate	2	Steel

⚠ Bolts for assembly are not indicated.

■ Table of Components (KCMSL700/800)

No.	Description	Qty	Material and Remark
①	Cam Slider	1	FC250
②	Cam Driver	1	FC250
③	Cam Holder	1	FC250
④	Cam Driver Plate A	2	Bronze with Graphite
⑤	Cam Driver Plate B	4	Bronze with Graphite
⑥	Spring Guide	2	Bronze with Graphite
⑦	Guide Pin Block	2	Steel
⑧	Spring Guide Plate	2	Steel
⑨	Positive Return Block	2	Bronze with Graphite
⑩	Positive Return Follower	2	S45C (1045 Hardened)
⑪	Key A	4	S45C (1045 Hardened)
⑫	Key B	6	Steel
⑬	Gas Spring	2	Refer to the spring type table.
⑭	Lower Plate A	2	S45C (1045 Hardened)
⑮	Lower Plate B	4	S45C (1045 Hardened)
⑯	Slide Lower Plate A	2	Bronze with Graphite
⑰	Slide Lower Plate B	2	Bronze with Graphite
⑱	Slide Lower Plate D	2	Bronze with Graphite
⑳	Center Key Guide	1	S45C (1045 Hardened)
㉑	Center Key	1	Bronze with Graphite
㉒	Stopper	4	Urethane
㉓	Base Plate A	2	S45C (1045 Hardened)
㉔	Base Plate B- L	1	S45C (1045 Hardened)
㉕	Base Plate B- R	1	S45C (1045 Hardened)

No.	Description	Qty	Material and Remark
㉖	Base Plate E- R	1	S45C (1045 Hardened)
㉗	Base Plate E- L	1	S45C (1045 Hardened)
㉘	Stopper Plate	2	Steel
㉙	Roller Bracket	1	Steel
㉚	Roller	1	S45C (1045 Hardened)
㉛	Roller Pin	1	S45C (1045 Hardened)
㉜	Bushing	1	SOB12-18-16
㉝	E Type Snap Ring	2	φ9
㉞	Roller Driver	1	S45C (1045 Hardened)
㉟	Lock Plate	2	Steel

⚠ Bolts for assembly are not indicated.

■ Table of Components (KCMSL900/1000)

No.	Description	Qty	Material and Remark
①	Cam Slider	1	FC250
②	Cam Driver	1	FC250
③	Cam Holder	1	FC250
⑤	Cam Driver Plate B	7	Bronze with Graphite
⑥	Spring Guide	4	Bronze with Graphite
⑦	Guide Pin Block	4	Steel
⑧	Spring Guide Plate	4	Steel
⑨	Positive Return Block	2	Bronze with Graphite
⑩	Positive Return Follower	2	S45C (1045 Hardened)
⑪	Key A	4	Steel
⑫	Key B	6	Steel
⑬	Gas Spring	4	Refer to the spring type table.
⑮	Lower Plate B	7	S45C (1045 Hardened)
⑯	Slide Lower Plate A	4	Bronze with Graphite
⑰	Slide Lower Plate B	4	Bronze with Graphite
⑱	Slide Lower Plate C	2	Bronze with Graphite
⑲	Base Plate B- R	1	S45C (1045 Hardened)
⑳	Center Key Guide	1	S45C (1045 Hardened)
㉑	Center Key	1	Bronze with Graphite
㉒	Stopper	8	Urethane
㉓	Base Plate A	4	S45C (1045 Hardened)
㉔	Base Plate B- L	1	S45C (1045 Hardened)
㉕	Base Plate C- L	1	S45C (1045 Hardened)

No.	Description	Qty	Material and Remark
㉖	Base Plate D	2	S45C (1045 Hardened)
㉗	Base Plate C- R	1	S45C (1045 Hardened)
㉘	Stopper Plate	4	Steel
㉙	Roller Bracket	2	Steel
㉚	Roller	2	S45C (1045 Hardened)
㉛	Roller Pin	2	S45C (1045 Hardened)
㉜	Bushing	2	SOB12-18-16
㉝	E Type Snap Ring	4	φ9
㉞	Roller Driver	2	S45C (1045 Hardened)
㉟	Lock Plate	2	Steel

⚠ Bolts for assembly are not indicated.