

Outline of Spherical Bushing Unit

Types and features of spherical bushing unit

There are 8 types of standard units according to the case shape, material and inner ring shape.

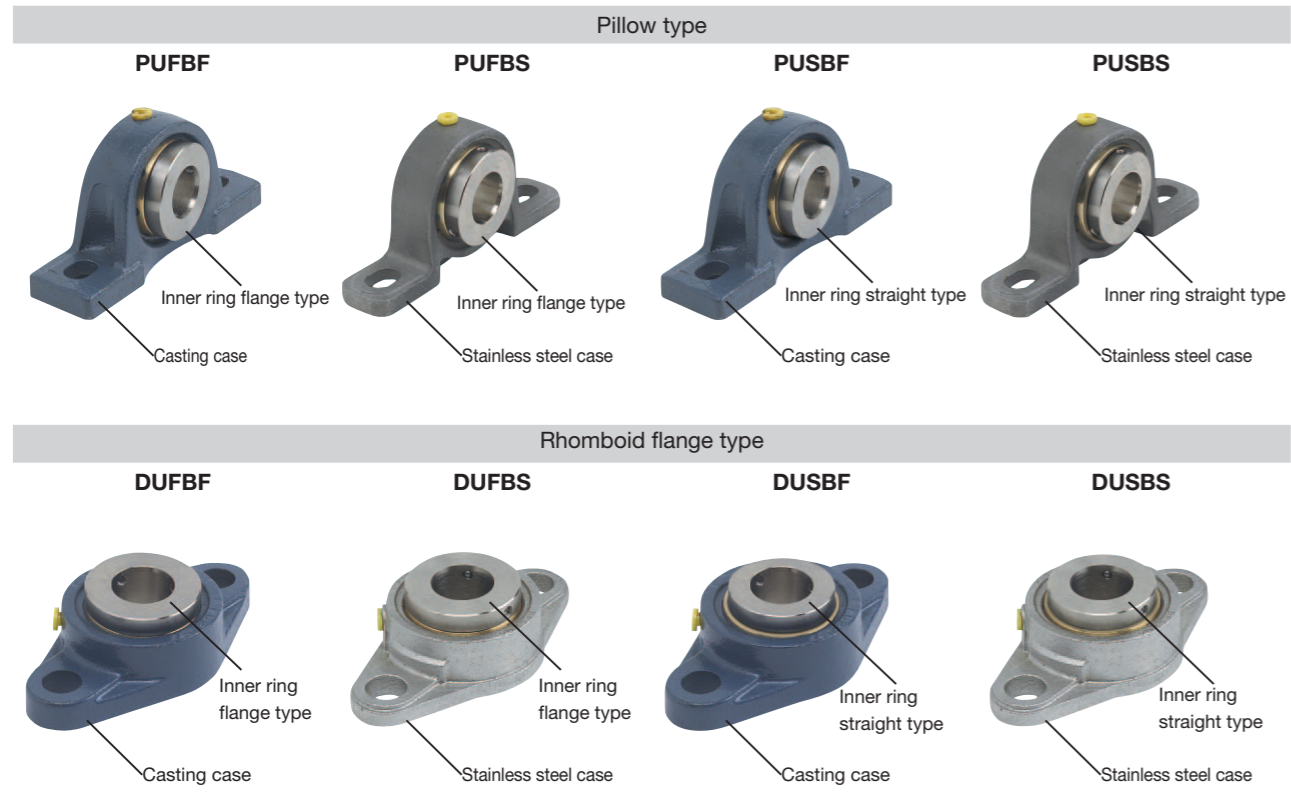

If you wish to have a case other than the shapes above, please contact our sales office.

The spherical bushing has two types of inner ring, flange and straight.

Flange type SBSF

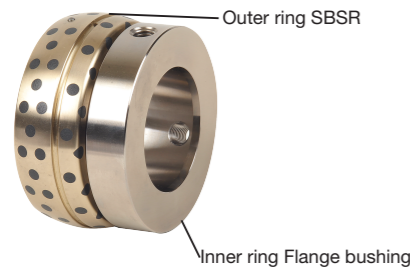

Straight type SBSS

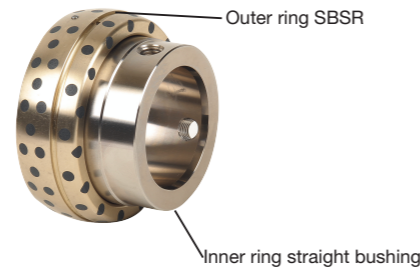

Features

- The unit can be used without lubrication.
- The unit can be used at the ambient temperature of -50 °C to +150 °C. (If bushing is used exceeding +150 °C, please contact our sales office.) The unit can be used under environment where dust or sand can easily enter.
- The unit can be used for rotation or oscillation.
- It is excellent in operation at high load and low speed.
- Flange type can withstand thrust load.
- The unit can be used without heat treatment or surface treatment on the shaft.
- Extension or shrink in the axial direction can be allowed.

Operation Range

Operation range of pillow type (operation range without lubrication, in the atmosphere and at normal temperature)

Case material	Case No.	Shaft diameter (d)	Maximum radial Load W (N)	Maximum Revolution N (rpm)	Allowable W-N Value (N · rpm)	Operation Temperature (°C)	Alignment Angle (°)
Gray Cast Iron Case	204	20	20000	170	9.5×10 ⁵	- 50~ 150	7
	205	25	23700	145	10.8×10 ⁵		6
	206	30	27500	115	12.7×10 ⁵		7
	207	35	32500	95	14.7×10 ⁵		6
	208	40	37500	80	15.2×10 ⁵		
	209	45	42500	70	15.2×10 ⁵		
Stainless steel case	210	50	43500	65	15.9×10 ⁵	- 50~ 300	6
	204	20	26500	170	9.5×10 ⁵		7
	205	25	31500	145	10.8×10 ⁵		6
	206	30	36500	115	12.7×10 ⁵		7
	207	35	43000	95	14.7×10 ⁵		
	208	40	43500	80	15.2×10 ⁵		
209	45	43500	70	15.2×10 ⁵			
210	50	43500	65	15.9×10 ⁵			

For thrust load of the inner ring flange type, use 1/10 of the radial load in the table above.

Operation range of rhomboid flange type (operation range without lubrication, in the atmosphere and at normal temperature)

Case material	Case No.	Shaft diameter (d)	Maximum radial Load W (N)	Maximum Revolution N (rpm)	Allowable W-N Value (N · rpm)	Operation Temperature (°C)	Alignment Angle (°)
Gray Cast Iron Case	204	20	5500	170	9.3×10 ⁵	- 50~ 150	7
	205	25	7000	145	10.1×10 ⁵		6
	206	30	8500	115	9.7×10 ⁵		7
	207	35	10000	95	9.5×10 ⁵		6
	208	40	11500	80	9.2×10 ⁵		
	209	45	13500	70	9.4×10 ⁵		
Stainless steel case	210	50	15000	65	9.7×10 ⁵	- 50~ 300	6
	204	20	11500	170	9.5×10 ⁵		7
	205	25	14000	145	10.8×10 ⁵		6
	206	30	17000	115	12.7×10 ⁵		7
	207	35	20000	95	14.7×10 ⁵		
	208	40	23500	80	15.2×10 ⁵		
209	45	27000	70	15.2×10 ⁵			
210	50	30500	65	15.9×10 ⁵			

For thrust load of the inner ring flange type, use 1/2 of the radial load in the table above.

- If the unit is used exceeding the temperature of 100°C, the operation range is different. (Refer to the graph below.)
- If the unit is used exceeding the temperature of 150 °C, the specification of the outer ring is different. Contact the sales representative.
- If the unit is used exceeding the temperature of 150°C, use the stainless case type.

Contact the sales representative for the following cases.

- The loading direction is not downward and A or B in the figure in the right.
- Operation is performed under the environment not specified in the table above.
- The outer ring material is changed.

Loading direction of Pillow Type

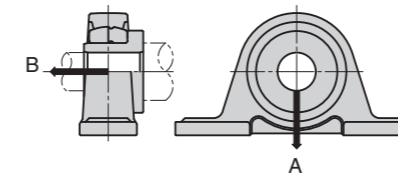

Loading direction of rhomboid Flange Type

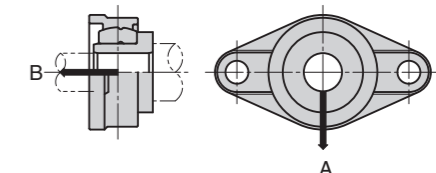

Reduction ratio of W and W-N values at operation temperature

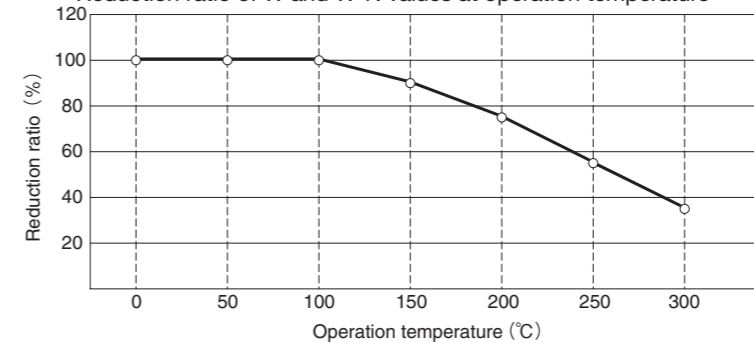

Outline of Spherical Bushing Unit

■ For operation of spherical bushing unit

(1) Assembly and fixing method of unit

Insert the unit at the specified position of the shaft.

Fix the inner ring and the shaft with set screws.

Fix the case with bolts.

- ⚠ · Make sure that the mating part for the unit is suitable for operating conditions.
- Be careful that there is no foreign matter or step on the mounting surface.
- When three units or more are used, align the shaft correctly.
(The tolerance should be ± 0.25 mm.)

(2) Fixing method of shaft and inner ring

Fix the inner ring at the position where the flange does not come in contact with the outer ring end. Fix it with the clearance of 0.1 mm as a guideline. If interference between the inner ring flange and the outer ring end due to thermal expansion/shrink of the shaft is concerned, adjust the clearance appropriately. (One straight type screw per position is used)

If the unit is used at a place or environment where vibration or impact is applied, provide seating at the set screw position of the shaft with a file or borer.

(3) For thrust load

If thrust load is applied, use the flange type inner ring. Solid lubricant is embedded at one side of the outer ring.

When a flange type is used, make assembly so that the flange area may match the solid lubricant surface at the side.

(4) For greasing

Grease groove is provided at the outer ring. Greasing can improve wear resistance and durability.

(5) Accuracy and design of shaft

The recommended tolerance of the mating shaft is g6. Since the inner ring slides with the outer ring, material and hardness of the shaft is not particularly important. Heat treatment of the shaft surface is not required either.

(6) Measures for heat generation

If the unit is used at high temperature, thermal expansion (thrust direction) of the shaft occurs. If the flange type inner ring is used, it is recommended to design the flange outside.

Spherical Bushing Set

Pillow Type



Inner Ring Flange Bushing
PUFBF (Gray Cast Iron Case)
PUFBS (Stainless steel case)

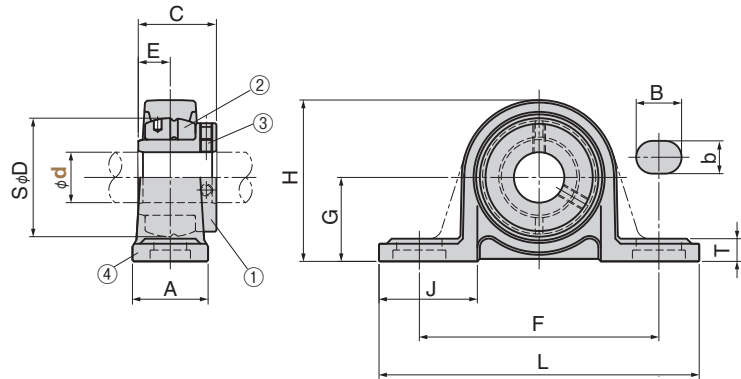

Inner Ring Straight Bushing
PUSBF (Gray Cast Iron Case)
PUSBS (Stainless steel case)

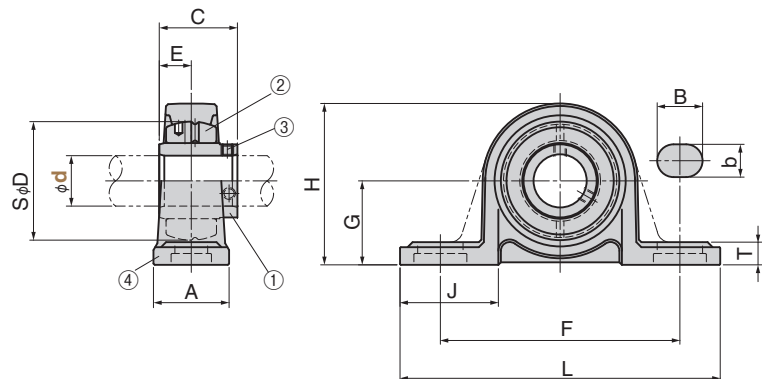

- Grease nipples are provided.
- Stopper pin for outer ring (SUJ2, 1pce) is attached.

Table of Components

No.	Description	Qty	Material and remark
①	Inner Ring	1	S45CNon-electrolytic nickel plating
②	Outer ring	1	Copper alloy with graphite (SO#50SP2)
③	Hexagon socket head set screw	4	SCM435(Straight bush is 2)
④	Case	1	Gray cast iron(FC200) Stainless(SCS13)

A	C	E	D	L	F	H	G	J	T	B	b	Mounting Bolt	Case No.	Catalog No.	d
38 (30)	31.0	12.7	47	127	95	64 (63)	33.3	38 (42)	13 (11)	18	13	M10	204		20
38 (30)	34.0	14.3	52	140	105	71 (69)	36.5	43 (46)	13 (12)	18 (19)	13	M10	205		25
48 (36)	38.1	15.9	62	165	121	84 (81)	42.9	53 (54)	15 (13)				206	Inner Ring Flange Bushing PUFBF	30
48 (38)	42.9	17.5	72	167	127	93 (91)	47.6	51	16 (14)	21	17	M14	207	Inner Ring Straight Bushing PUFBS	35
54 (40)	49.2		80	184	137	98 (97)	49.2	57 (60)	17 (14)				208	PUSBF	40
54 (40)	49.2	19.0	85	190	146	106 (104)	54.0	60 (61)	17 (15)				209	PUSBS	45
60 (45)	51.6		90	206	159	113 (111)	57.2	63 (65)	19 (16)	22	20	M16	210		50

Values in () are for the stainless steel case.



Order

Catalog No. **PUFBF**
 d **30**

- The stainless steel case (PUFBS and PUSBS) are built-to-order product.