

# Guide Post

PRESS-FIT TYPE

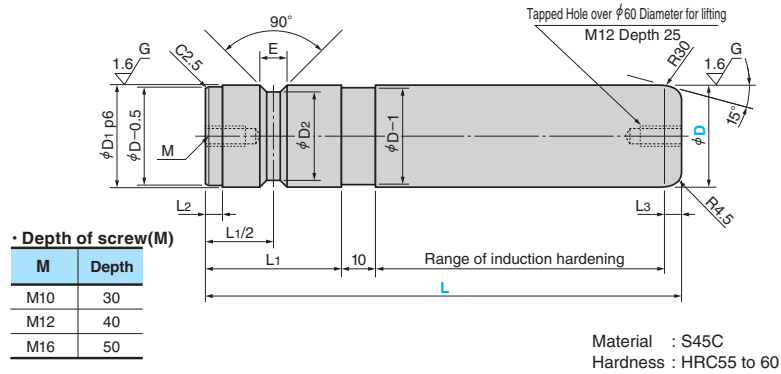

SGP



D Tolerance	D1	p6	D2	L1	L2	L3	E	M	Catalog No.	D	L
25	25		21	30				10	SGP	25	80
											100
											120
											140
											160
30	30	+0.035 +0.022	26	40	5	5	8		SGP	30	120
											140
											160
											180
											200
40	40	-0.005 -0.015	36	50				12	SGP	40	140
											160
											180
											200
											250
50	50	+0.042 +0.026	45	70				10	SGP	50	200
											250
											300
											350
											400
60	60	-0.010 -0.025	55	90					SGP	60	250
											300
											350
											400
											450
65	65	+0.051 +0.032	60	100	10	10			SGP	65	250
											300
											350
											400
											450
80	80	-0.010 -0.025	75	120					SGP	80	300
											350
											400
											450
											500
100	100	+0.059 +0.037	95	150					SGP	100	300
											350
											400
											450
											500

Order   -   
SGP 50 - 250

## Pulling washer for guide post

GPHW

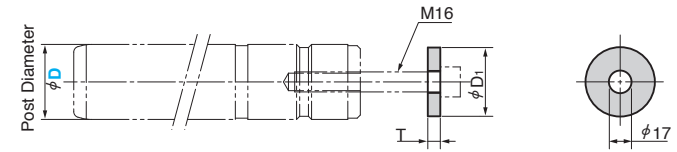

Material : SS400

D1	T	Catalog No.	D (Post Diameter)
55	10	GPHW	60
75			80
95	15		100



Order

GPHW 80



Option

Option Code	Specification
HW	An M16 tapped hole with a depth of 50 for pulling is drilled on the outer end surface of the press fitting section. The GPHW tension washer for guide post is included.



Order

SGP 80 - 250 - HW