

Guide Post

GUIDE POST

Addition

CAD
FILE

GPTB

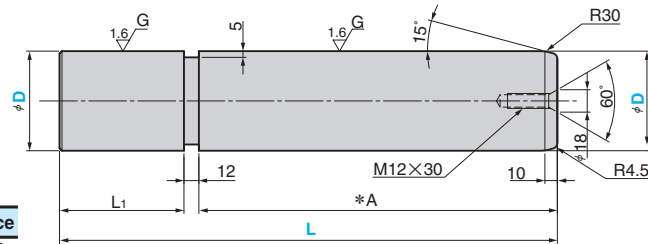

D	Tolerance
60	-0.010 -0.020
80	-0.010
100	-0.025
120	

*Induction hardening at A

Material : S45C
Hardness : HRC55 to 60
(Induction hardening at A)

L1	Catalog No.	D	L
			250
80		60	300
			350
100	GPTB	80	350
			400
			350
120		100	400
			450
150		120	450

Order - -

Guide Post · Loosening Lock Washer

WASHER FOR GUIDE POST

Addition

CAD
FILE

GPTS

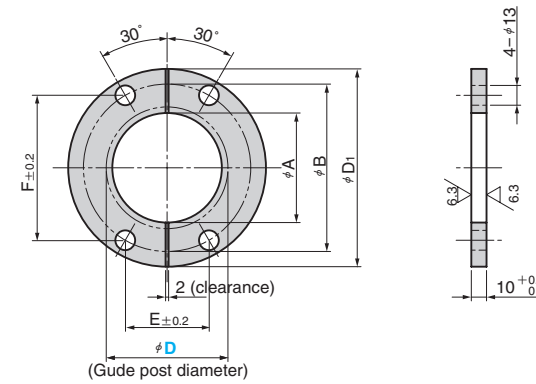

Material : STKM13A

A	B	D1	E	F	Catalog No.	D
52	90	110	45	77.9		60
72	110	130	55	95.3	GPTS	80
92	130	150	65	112.6		100
112	156	177.8	78	135.1		120



Order

Catalog No. D