

Guide Bar

WEAR PLATE TYPE

CAD
FILE

GBTP(Bronze Plate Type)

GBTX(Sintered Plate Type)

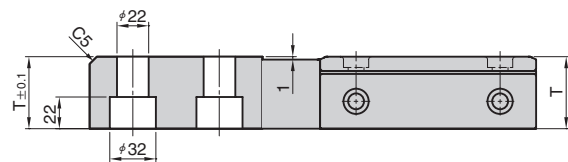
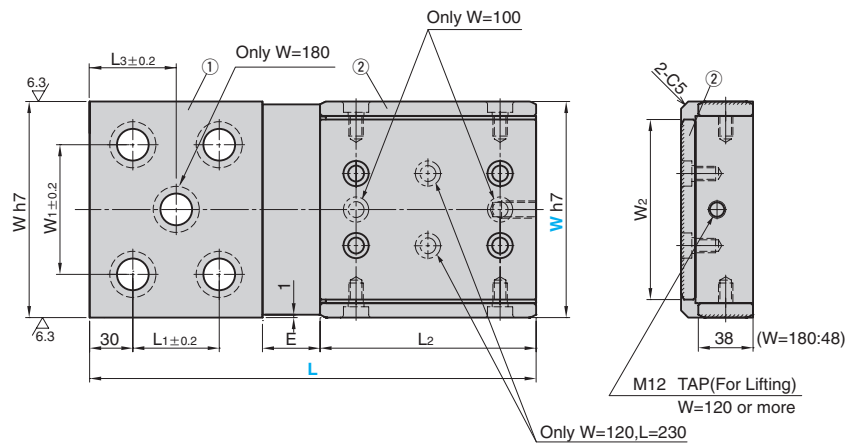

● Sliding Direction



Material
 ① Main body SS400
 ② Wear plate GBTP : Bronze with graphite (TWP)
 GBTX : Sintered copper alloy (TWX)

W h7	W ₁	W ₂	L ₁	L ₂	L ₃	T	E	Catalog No.	W	L	
100		75	60	75			35		100	230	
			100	125			45			280	
			120	150			60			330	
120	60	100	60	75	45		35	GBTX	120	230	
			100	125			45			280	
			120	150			60			390	
			140	180			80			430	
150	90	125	60	125		50	35	GBTX	150	280	
			100	150			45			330	
			120	180			60			390	
180	120	150	60	125	60	55	35	GBTX	180	280	
			100	150			80			45	330
			120	180			90			60	390
			140	180	100		80			430	



Order

Catalog No.	W	-	L
GBTP	100	-	280
GBTX	150	-	330

For Operation

- When the sliding surface is damaged by scratches or dents, it can be repaired by just replacing each plate.
- See TWP on page 131 for details on GBTP plate.
See TWX on page 125 for details on GBTX plate.
- When replacing a plate, the dimensions are not necessarily the initial dimensions. Adjust the dimensions by grinding or adding shims before use. Also, when grinding the plate, grind the bottom surface.