

# Wear Plate

Thickness 10 mm

SINTERED TYPE

CAD FILE

TWX

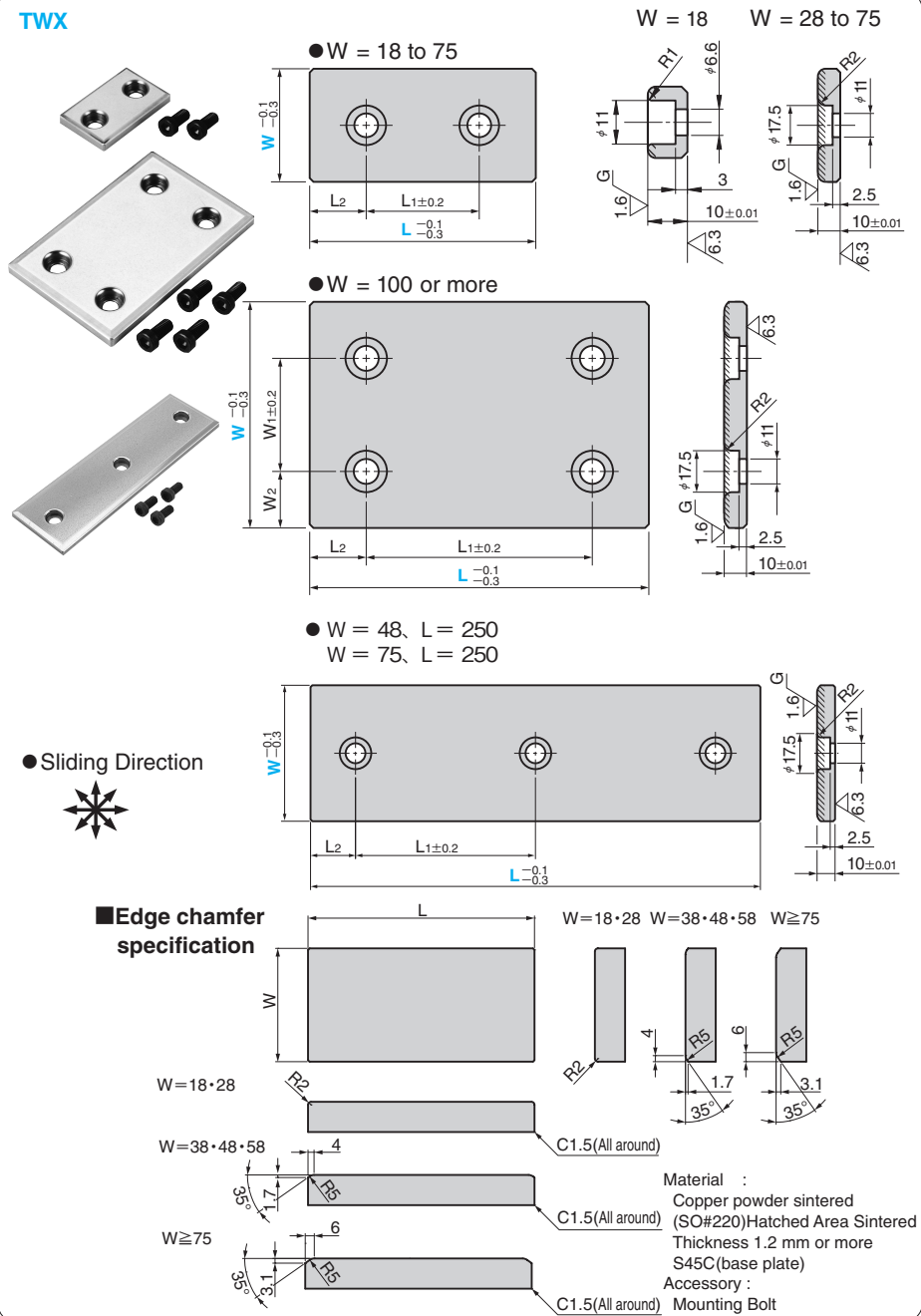

W <sub>1</sub>	W <sub>2</sub>	L <sub>1</sub>	L <sub>2</sub>	Catalog No.	W	L
		45	15			75
		50			18*	100
		75	25			125
		100				150
		45	15			75
		50			28	100
		75	25			125
		100				150
		45	15			75
		50			38	100
		75	25			125
		100				150
-	-	45	15			75
		50				100
		75	25		48	125
		100				150
		100	50			200
			25			250
		45	15			75
		50		TWX	58	100
		100				150
		25				75
		50				100
		75	25		75	125
		100				150
		150				200
		100				250
		50				100
		75				125
50	25	100	25		100	150
		150				200
		200	50			300
75		75				125
		100				150
50	37.5	150	25		125	200
		200				250
			50			300
		100				150
100	25	150	25		150	200
		200				250

● Special brazier head bolt

(LCS standard)  
LCS10-20

\*Bolts are not attached to TWX18.



Order

Catalog No. TWX W - L  
48 - 150

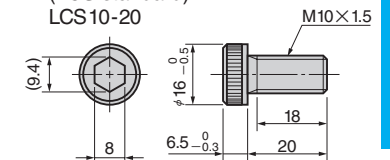

■ We are ready to accept requests or orders for special parts.

Copyright © Sankyo Oilless Industry, Inc. All Rights Reserved.

# Wear Plate

Thickness 10 mm

SINTERED TYPE

CAD  
FILE

TWXT (2-hole Type)

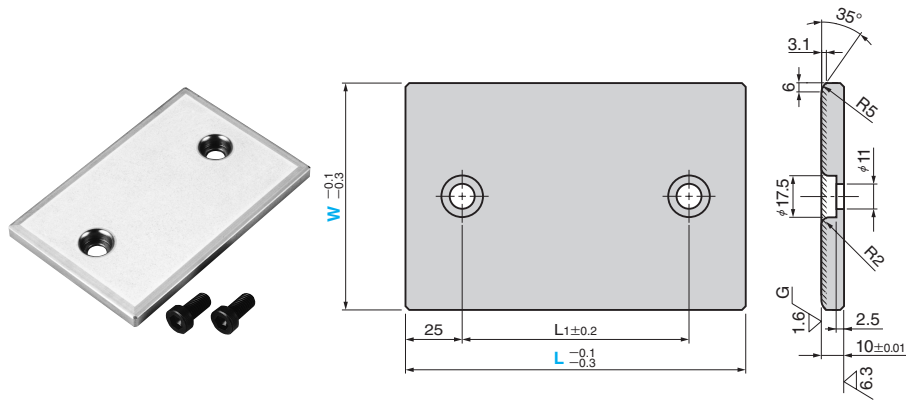

See Page 129 for corner chamfering.

● Sliding Direction



● Special brazier head bolt (LCS standard)  
LCS10-20

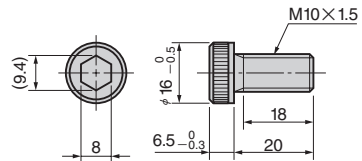

Material : Copper powder sintered  
(SO#220)

Hatched Area Sintered  
Thickness 1.2 mm or more  
S45C(base plate)

Accessory : Mounting Bolt

L1	Catalog No.	W	L
50			100
75			125
100		100	150
150			200
200			250
75	TWXT		125
100		125	150
150			200
200			250
100		150	150
150			200
200			250



Order

Catalog No. TWXT  
W 125 - L 125