

Shim Plate

FOR WEAR PLATE

SHMS

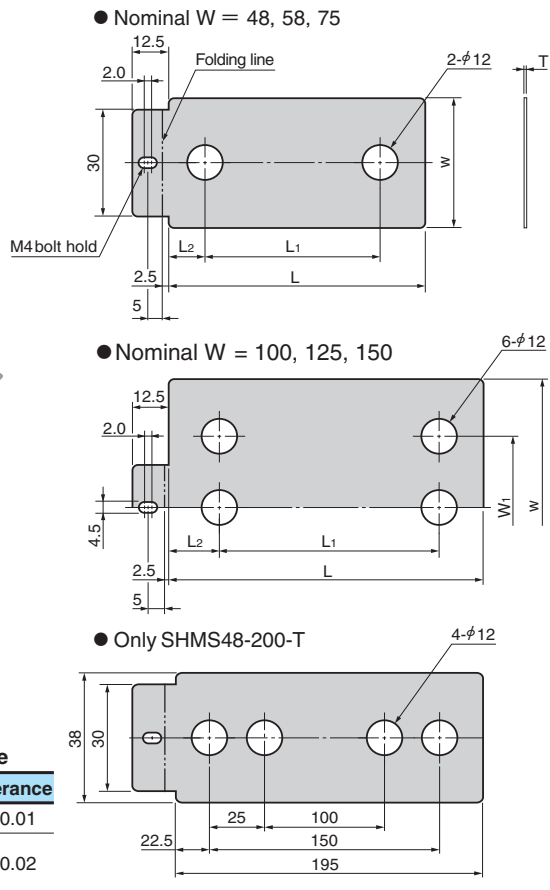

Material : SUS304

NOTES:

- SHMS can work for the Wear Plates with thickness 10 or 20 having 2 or 4 holes.
- Ensure to drill M4 tapped holes at a folding area on the Wear Plate so the shim will not be lost.

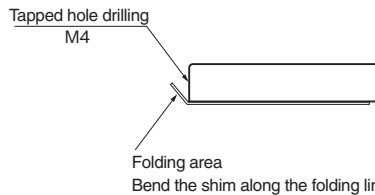

W1	L1	L2	w	L	Catalog No.	Nominal (wear plate)		Thickness T
						W	L	
	45	12.5		70			75	
	50			95			100	
	75		38	120		48	125	
	100	22.5		145			150	
	150			195			200	
	45	12.5		70			75	
	50		48	95		58	100	
	100			145			150	
	25			70			75	0.03
	50			95			100	
	75		65	120		75	125	0.05
	100			145			150	
	150			195	SHMS		200	0.1
	50			95			100	
	75			120			125	0.2
	100	22.5	90	145		100	150	
	150			195			200	0.3
50	200			245			250	
	75			120			125	
	100		115	145		125	150	
	150			195			200	
	200			245			250	
100	100			145			150	
	150		140	195		150	200	
	200			245			250	



Order

Catalog No. SHMS W 48 - L 125 - T 0.1



Attention: 0.03, 0.05, and 0.1 are sold in a set of 10 pcs.