

Cam Center Gib/Cam Center Block

FOR CAM SLIDER

CAD FILE

SFCU
(Steel with Graphite Type)

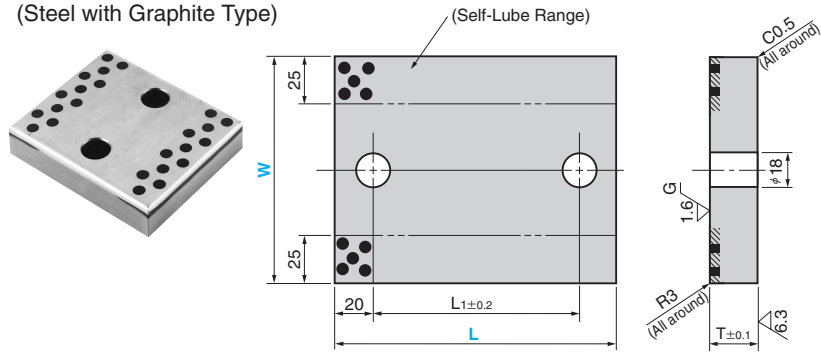

Material : S45C with Graphite
Hardness: HRC40 or more
Area to be Induction Hardened (Hatched Area)

SFCUB

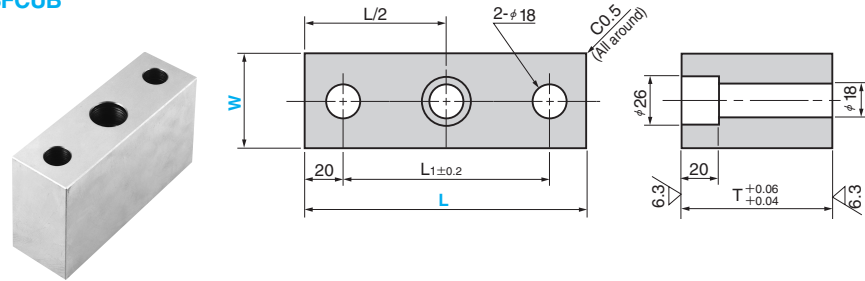

Material : SS400

SFCX
(Sintered Type)

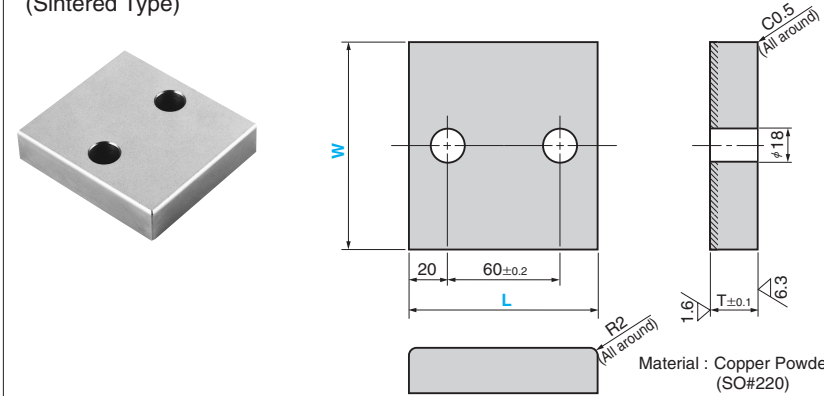

Material : Copper Powder Sintered (SO#220)
Hatched Area Sintered
Thickness: 1.2 mm or more
SS400(base plate)

SFCXB

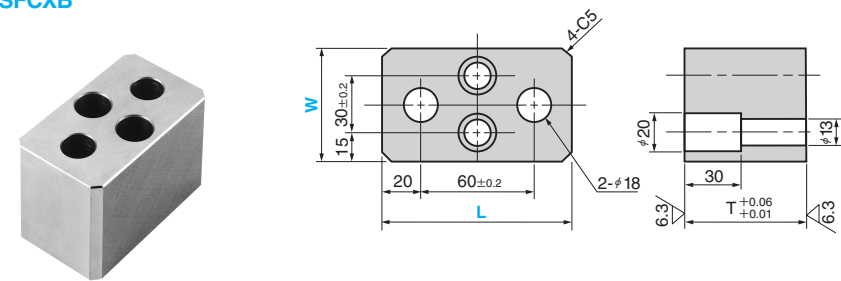

Material : SS400

T	L ₁	Catalog No.	W	L
25	60	SFCU	120	100
	110			150
80	60	SFCUB	50	100
	110			150

Order

Catalog No.	W	-	L
SFCU	120	-	100

T	Catalog No.	W	L
25	SFCX	110	100
65	SFCXB	60	100

Order

Catalog No.	W	-	L
SFCX	110	-	100

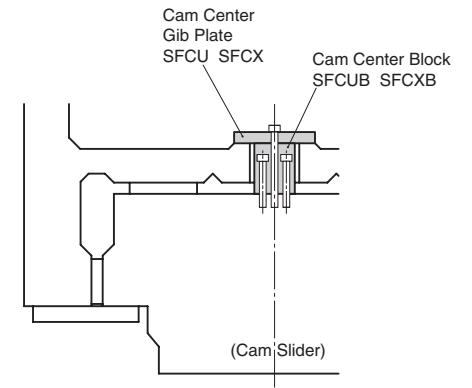

■ We are ready to accept requests or orders for special parts.