

Cam Positive Return Plate

BRONZE WITH GRAPHITE TYPE

CAD FILE

CPRP
CPRPR
CPRPL

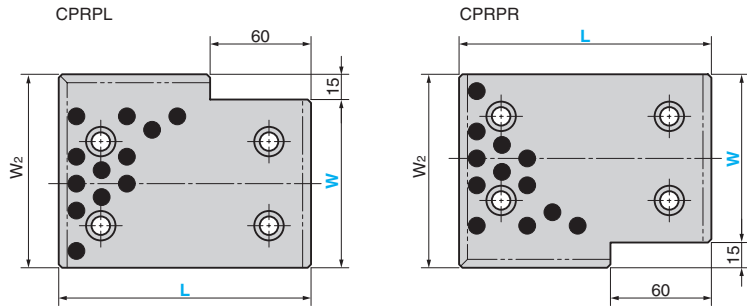
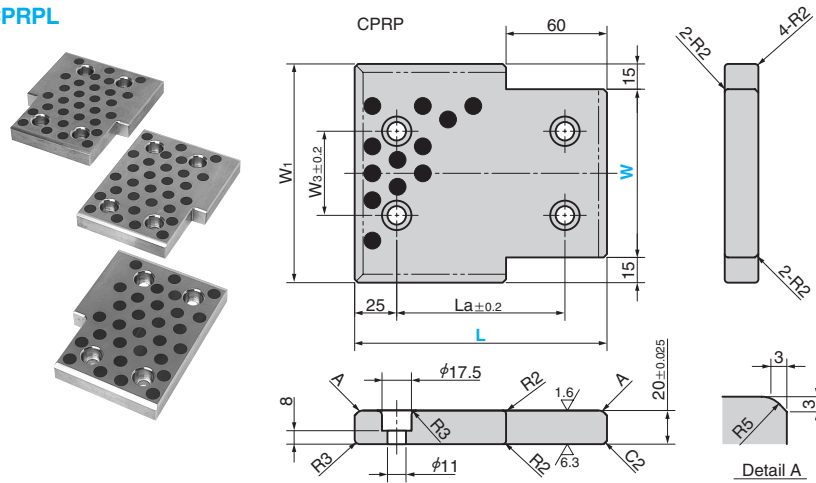

● Sliding Direction
↔

Material : Bronze with Graphite (SO#50 SP2)

W1	W2	W3	La	Catalog No.	W	L
105	90	40	50		75	100
			75			125
			100			150
130	115	50	75	CPRP	100	125
			100			150
			100			150
155	140	75	150	CPRPR	125	200
			200			250
			150			200
180	165	100	150		150	200
			200			250



Order

Catalog No.	W	L	
CPRP	125	200	▲ L = 250 is made to order.
CPRP	125	200	- SC80
CPRP	125	200	- TTC
CPRP	125	200	- SC80-TTC



Option

Option Code	Specification
SC	The notch length extended in 1 mm increments between $61 \leq SC \leq L-30$.
TTC	Sheet thickness tolerance changed to ± 0.01 .

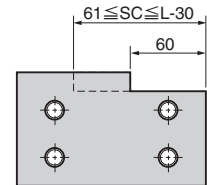

SC Specification Drawing



Example

