

DA Gauge

DISAPPEARING GAUGE

CAD FILE

DABT

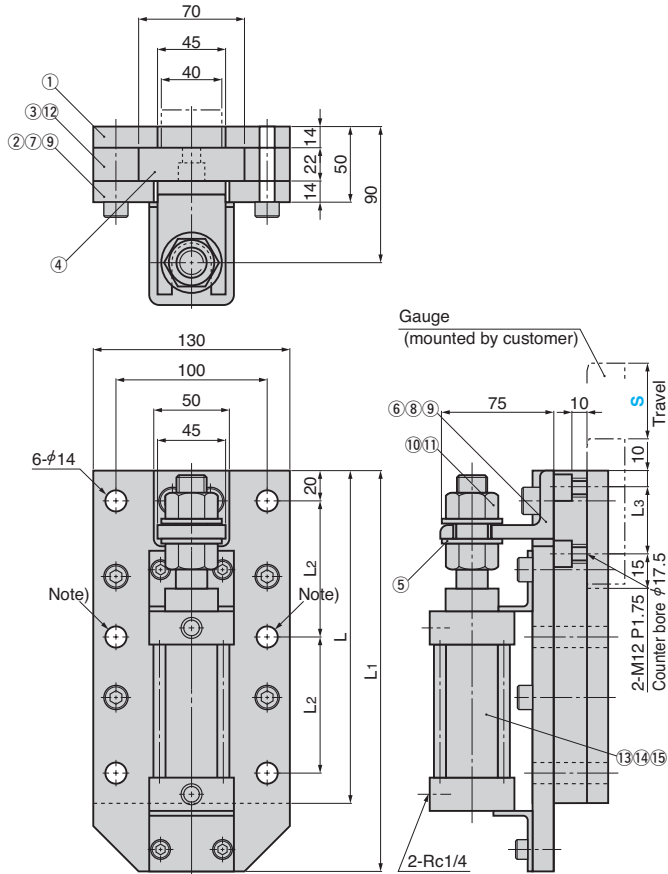

Note) This bolt hole is not available for DABT50.

L	L ₁	L ₂	L ₃	Weight(kg)	Catalog No.	S
220	265	90	25	13.5		50
270	315	115	45	15.9	DABT	100
320	365	140	95	18.3		150



Order

Catalog No.	S
DABT	150

For Operation

- Use DA gauge "DABT" as the panel locator for a draw die.
- Sliding areas have lubricant for oilless operation.
- The bolt holes of the sliding plate (4) are threaded so that the gauge may be mounted from the gauge side. (Dimension L₃)

Table of Components

No.	Description	Qty	Material and Remark	No.	Description	Qty	Material and Remark
①	Base Plate	1	SS400	⑨	Spring Washer	4	For M10
②	Cover Plate	1	SS400	⑩	Washer	2	
③	Side Plate	2	SS400	⑪	Lock Nut	1	U nut
④	Slide Plate	1	S45C Oilless Type	⑫	Dowel Pn	4	φ10×30
⑤	Collar	1	SS400	⑬	Spring Pin	1	φ6×15
⑥	Arm	1	SS400	⑭	Hexagon Socket Head Bolt	4	M8×16
⑦	Hexagon Socket Head Bolt	4	M10×50	⑮	Air Cylinder	1	D-MCY-F40 by Taiyo
⑧	Hexagon Socket Head Bolt	2	M12×25				