

DA Gauge

SWIVEL TYPE

CAD
FILE

DART

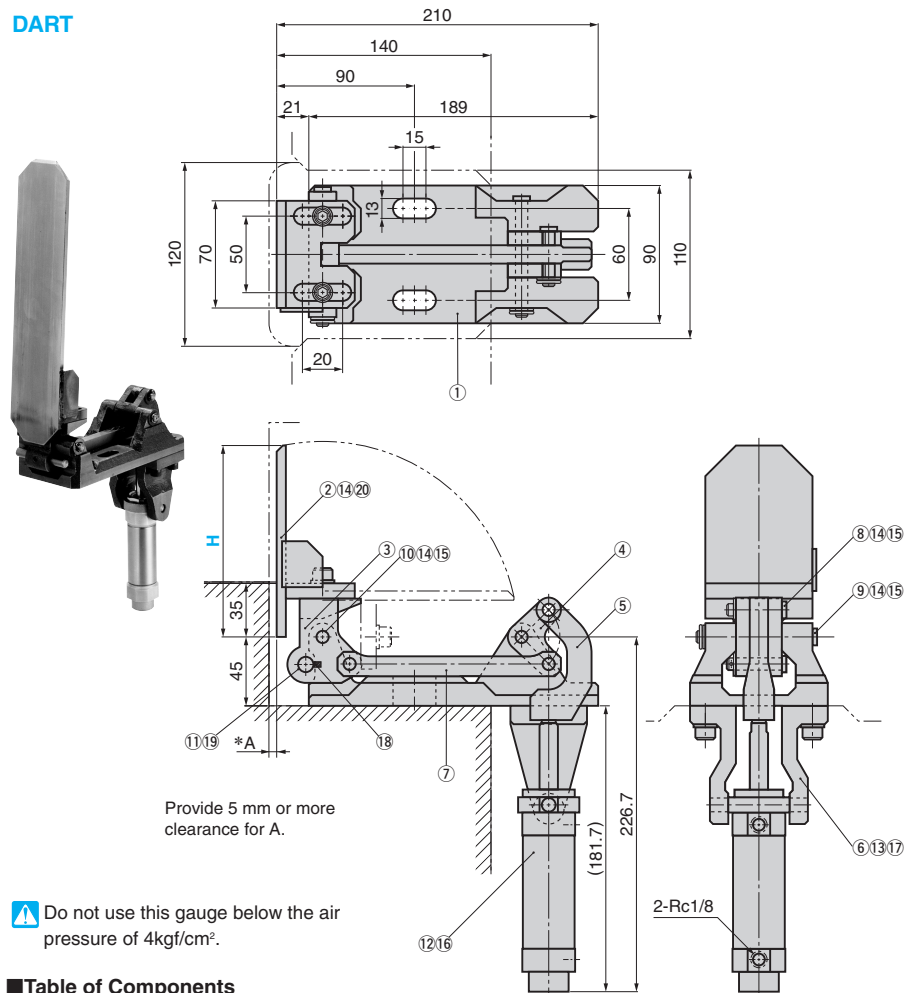

⚠ Do not use this gauge below the air pressure of 4kg/cm².

Table of Components

No.	Description	Qty	Material and Remark	No.	Description	Qty	Material and Remark
①	Gauge Base	1	FCD540	⑪	Stopper Pin	1	SCM435
②	Stopper Plate	1	SS400	⑫	Air Cylinder	1	CM2U32-35A(SMC)
③	Gauge Bracket	1	FCD540	⑬	Hexagon Socket Head Bolt	4	M8×25
④	Joint	1	FCD540	⑭	Washer	7	For M8
⑤	Arm	1	FCD540	⑮	Cotter Pin	5	φ2×16
⑥	Cylinder Support	2	FCD540	⑯	Cotter Pin	1	φ3×30
⑦	Rod	1	SS400	⑰	Spring Washer	4	For M8
⑧	Joint Pin (S)	3	S45C	⑱	Stopper	2	φ8×6
⑨	Joint Pin 1	1	S25C	⑲	Hexagonal Socket Set Screw	1	M6×8
⑩	Joint Pin 2	1	S45C	⑳	Hexagon Socket Head Bolt	2	M8×20

Catalog No.	H
	75
	100
	125
DART	150
	175
	200
	225
	250

Order	Catalog No.	H
	DART	150

⚠ DART is made to order.