

# For rapid production Sheet Support Gauge

WEIGHT ADJUSTING TYPE

**NEW** CAD FILE

FKGNH

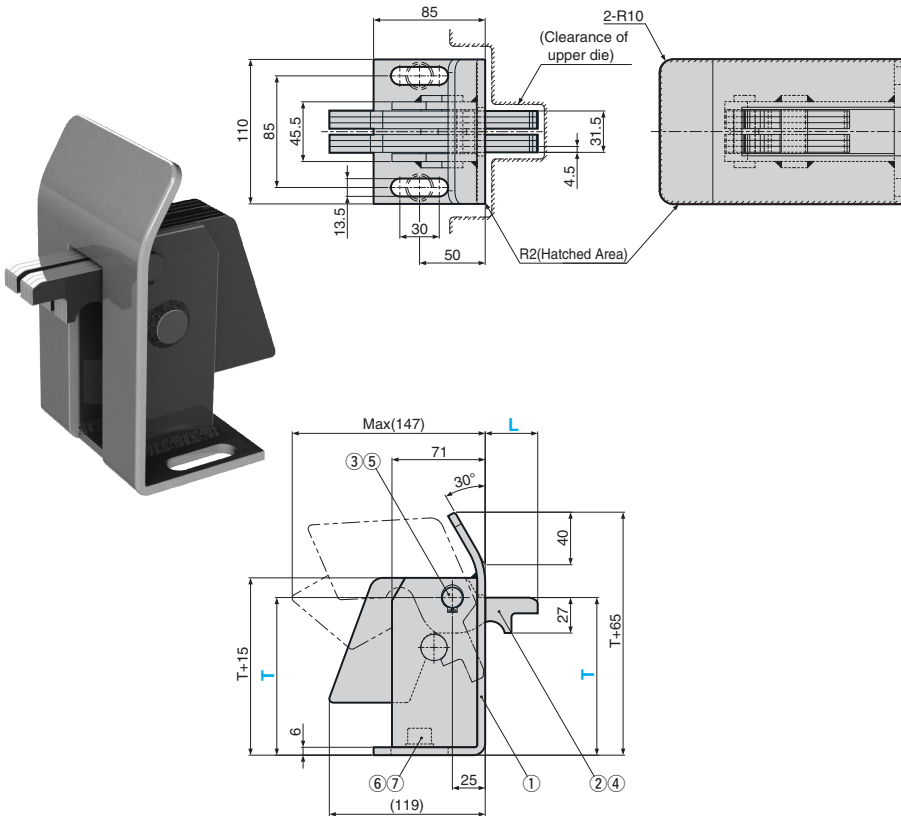

## Table of Components

No.	Description	Qty	Material and Remark
①	Gauge	1	Steel
②	Support Plate	6	Steel
③	Fulcrum Hinge Pin	1	Steel
④	Collar	5	1 piece is assembled. 4 pieces are accompanied.
⑤	C Type Retaining Ring	2	For $\phi 16$ Shaft
⑥	Hexagon Socket Head Cap Screw	2	M12x30 (Accessory)
⑦	Washer	2	For M12 (Accessory)

Catalog No.	T	L
	90	
FKGNH	120	20
	150	40
	180	



Order

Catalog No.	T	L
FKGNH	90	40

\* Workpiece guide block, which the previous model FKGN had, is not installed in FKGNH.  
FKGNH with work guide block is upon request.

## Support Plate

Catalog No.	L
STLPH	20
	40



Order

Catalog No.	L
STLPH	20

## Features

- Decreases the damage caused when setting a blank material.
- The number of support plates is adjustable up to 6 plates to equalize the weight of a blank material and support plates.

## For Operation

- Approximately 10 mm of clearance is required on the upper die to avoid contacting the gauge body and support plates.
- The load of approximately 500 g per a plate is required to swing the support plates.

## Exploded View

