

Nest Gauge

16mm THICK TYPE. REGULAR

CAD
FILE

NGLA
NGLSA (Gauge Hardening Type)

NGLR
NGLSR (Gauge Hardening Type)

NGLL
NGLSL (Gauge Hardening Type)

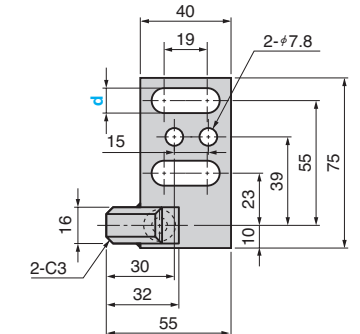
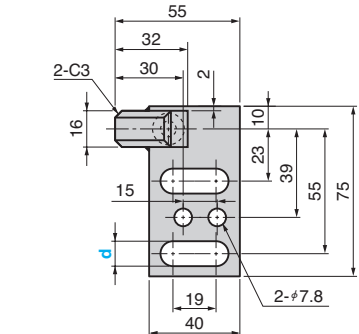
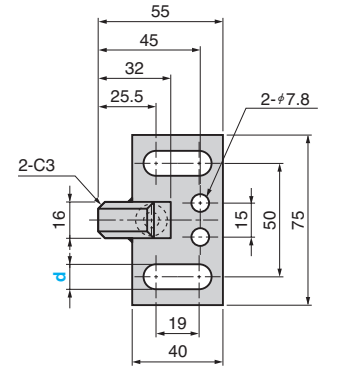

*Hardening
Type
NGLSA
NGLSR
NGLSL

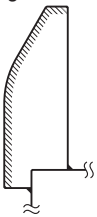

Hatched Area Hardening HRC45~

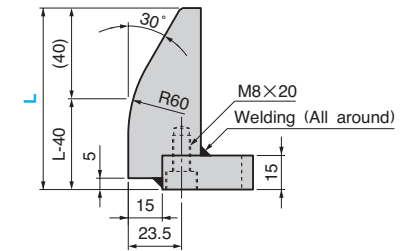
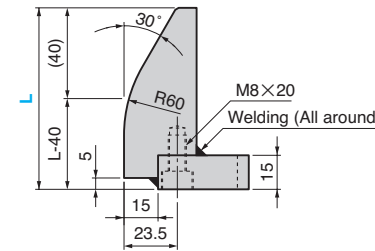
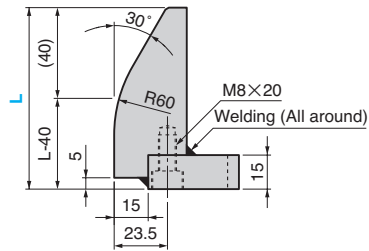

Material : Gauge S45C
Gauge base SS400
Accessory: Mounting bolt M10(M12)×30 2 pieces
Washer For M10(M12) 2 pieces

Catalog No.	L Increments of 5 mm	d
NGLA NGLSA	65~100	11
NGLR NGLSR	105~150	13
NGLL NGLSL	155~200	

Order -
 -