

# Nest Gauge

16mm THICK TYPE. ECONOMY

CAD  
FILE

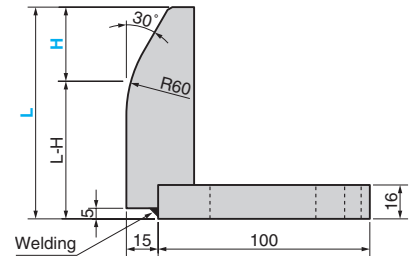
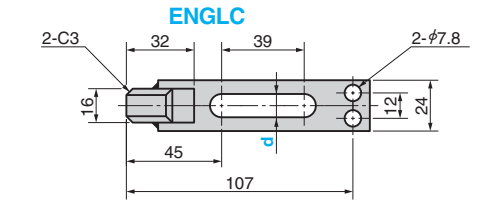
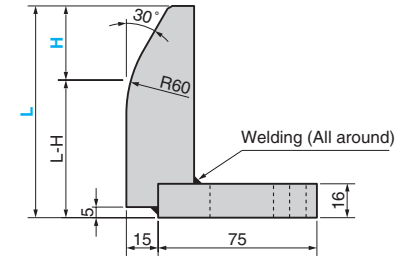
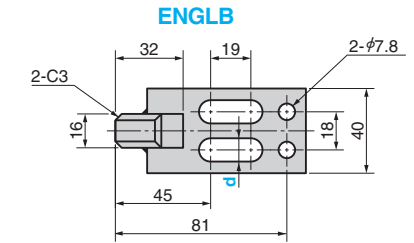
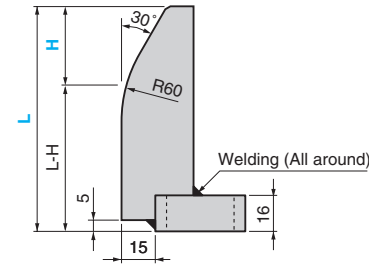
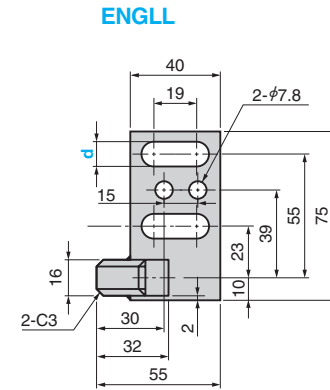
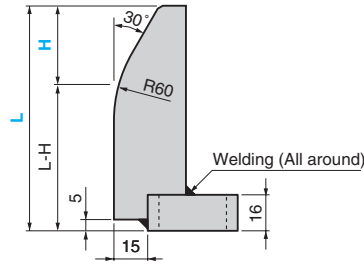
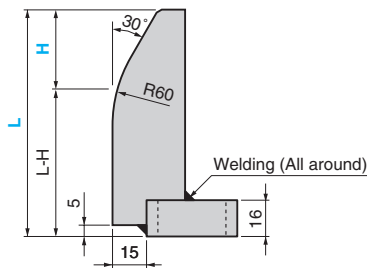
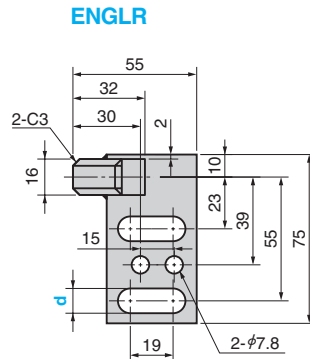
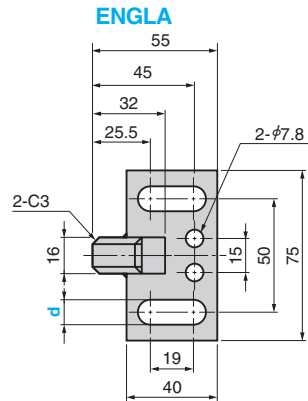

Material : Gauge SS400  
Gauge base SS400  
Accessory : Mounting bolt M10(M12)×30 2 pieces  
Washer For M10(M12) 2 pieces

Catalog No.	L Increments of 5 mm	H Increments of 5 mm	d*
ENGLA ENGLB	65~100		11
ENGLR ENGLC	105~150	20~40	13
ENGLL	155~200		



Order

Catalog No. **L** - **H** - **d\***  
**ENGLA 150 - 25 - 13**

\* ENGLB type is only for d = 11.