

Cam Slide Guide V-Shaped Guide Type

NAAMS STANDARD

CAD FILE

U Block SNG98 Series

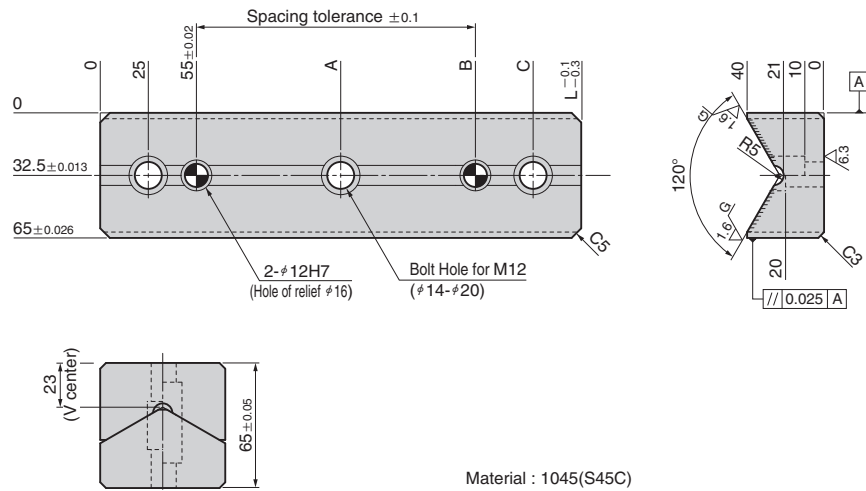

Material : 1045(S45C)
Area to be Induction Hardened(Hatched Area)
HRC55~60

V Block SNG97 Series

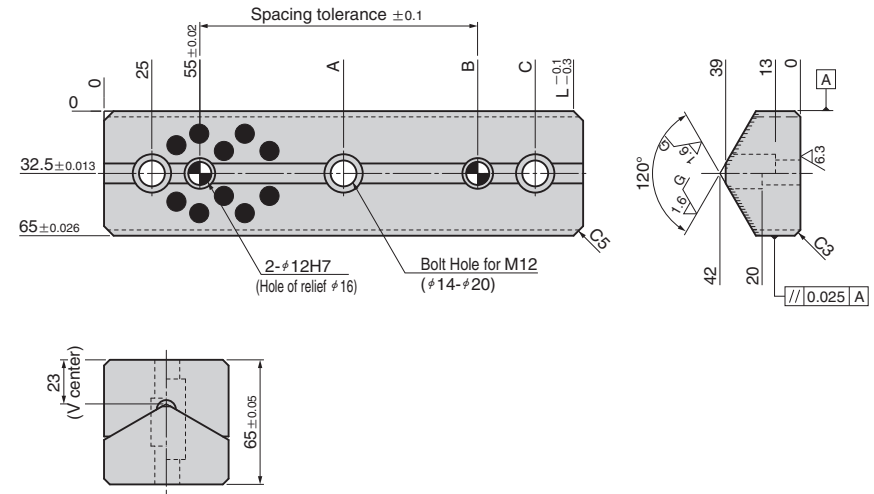

Material : Bronze with Graphite (SO#50 SP2)

No. of Holes	L	A	B	C	NAAMS Code	Catalog No.	
						Series Name	No.
2	150	—	100	125	G986515	SNG98	6515
	200	—	150	175	G986520		6520
3	250	125	200	225	G986525		6525
	300	150	250	275	G986530		6530

No. of Holes	L	A	B	C	NAAMS Code	Catalog No.	
						Series Name	No.
2	150	—	100	125	G976515	SNG97	6515
	200	—	150	175	G976520		6520
3	250	125	200	225	G976525		6525
	300	150	250	275	G976530		6530

Order
SNG98 **6520** (SNG986520)

SNG98 Series is made to order.

Order
SNG97 **6520** (SNG976520)

SNG97 Series is made to order.