

Cam Slide Guide V-Shaped Guide Type

NAAMS STANDARD

CAD FILE

U Block

SNG99 Series

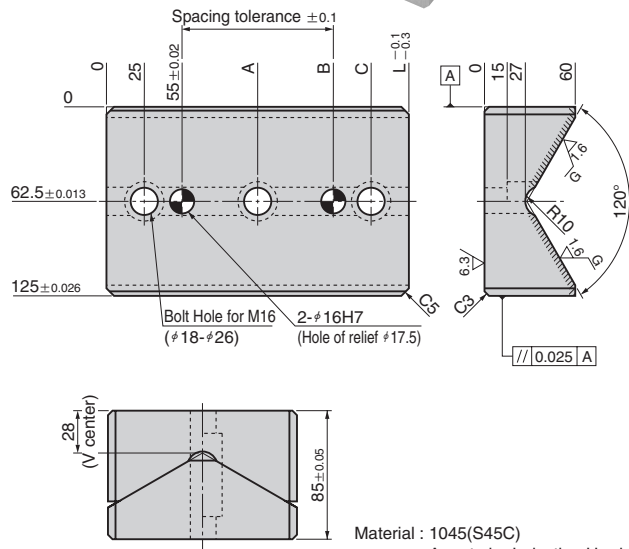

Material : 1045(S45C)
Area to be Induction Hardened(Hatched Area)
HRC55~60

V Block

SNG100 Series

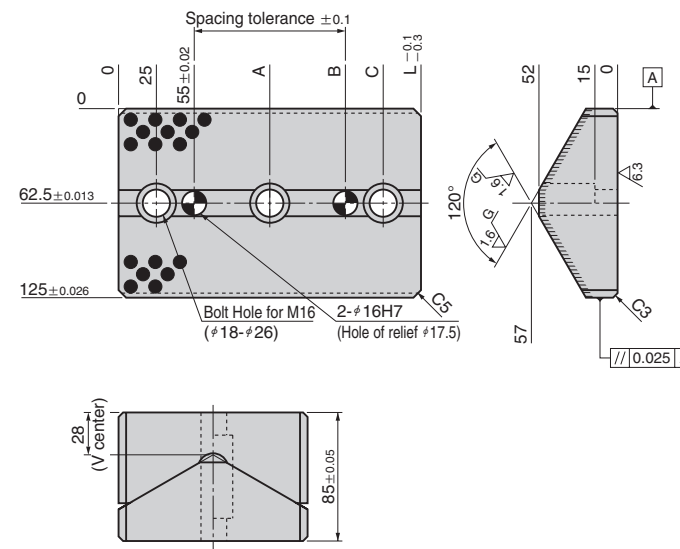

Material : Bronze with Graphite (SO#50 SP2)

No. of Holes	L	A	B	C	NAAMS Code	Catalog No.	
						Series Name	No.
2	150	—	100	125	G991215	SNG99	1215
	200	—	150	175	G991220		1220
3	250	125	200	225	G991225		1225
	300	150	250	275	G991230		1230

No. of Holes	L	A	B	C	NAAMS Code	Catalog No.	
						Series Name	No.
2	150	—	100	125	G1001215	SNG100	1215
	200	—	150	175	G1001220		1220
3	250	125	200	225	G1001225		1225
	300	150	250	275	G1001230		1230



Order

Catalog No.

Series Name No.

SNG99 1225 (SNG991225)

▲ SNG99 Series is made to order.



Order

Catalog No.

Series Name No.

SNG100 1225 (SNG1001225)

▲ SNG100 Series is made to order.