

SNR11 Series

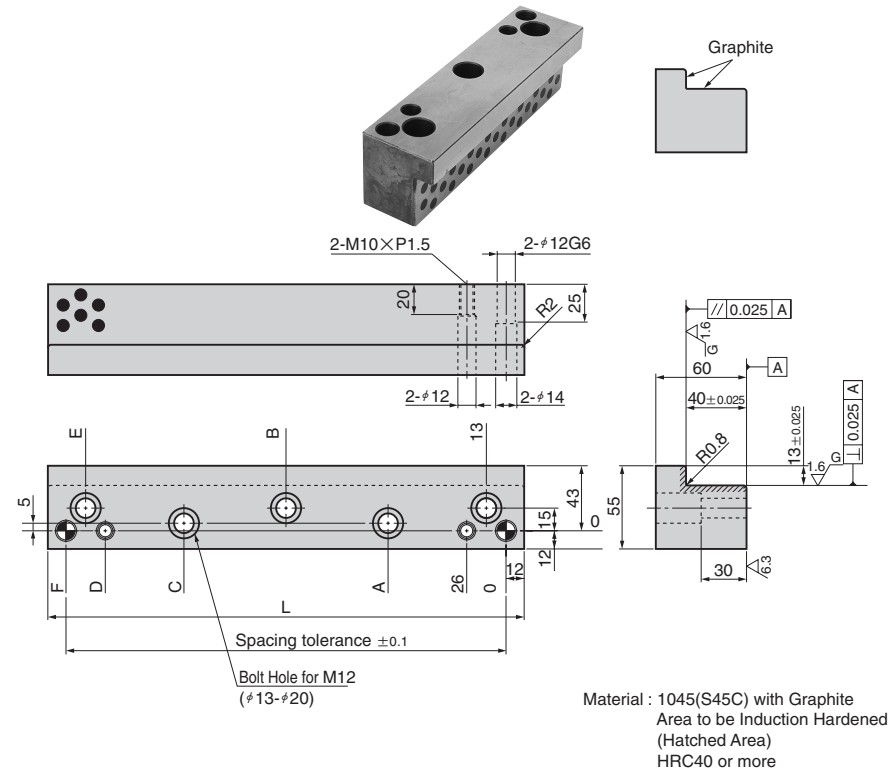

No. of Holes	A	B	C	D	E	F	L	NAAMS Code	Catalog No.	
									Series Name	No.
3	68	—	—	110	123	136	160	R114016	SNR11	4016
	88	—	—	150	163	176	200	R114020		4020
4	—	—	148	200	213	226	250	R114025	SNR11	4025
	78	145.5	213	265	278	291	315	R114031		4031



Order

Catalog No.	
Series Name	No.
SNR11	4016

(SNR114016)

SNR11 Series is made to order.

SNR12 Series

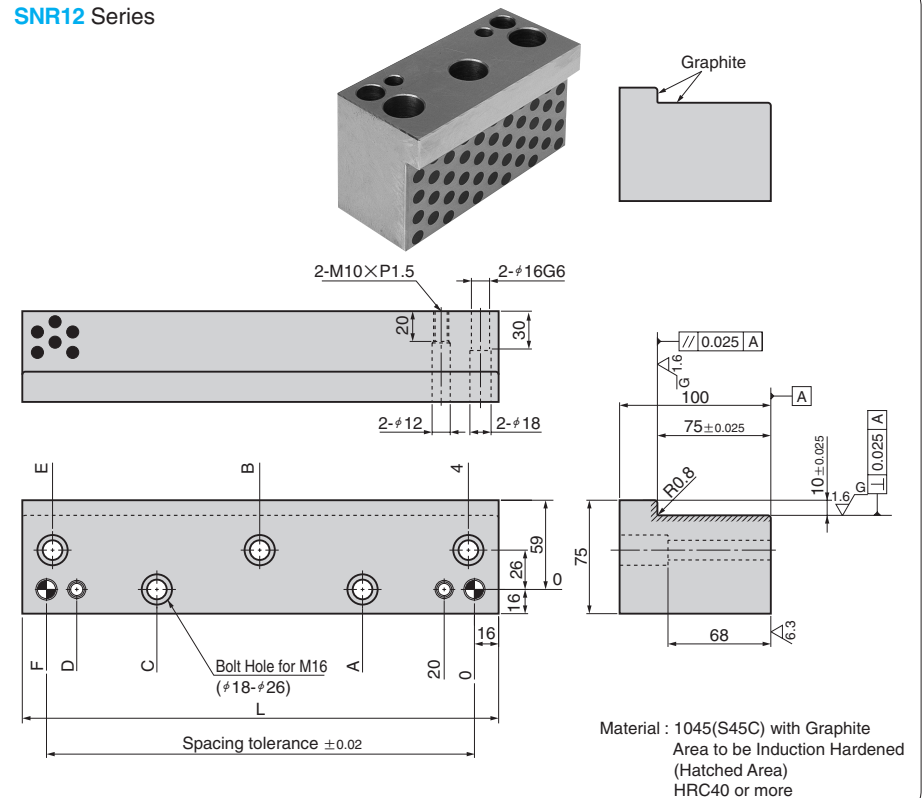

No. of Holes	A	B	C	D	E	F	L	NAAMS Code	Catalog No.	
									Series Name	No.
3	—	64	—	108	124	128	160	R127516	SNR12	7516
	—	84	—	148	164	168	200	R127520		7520
4	—	—	144	198	214	218	250	R127525	SNR12	7525
	74	142	210	263	279	283	315	R127531		7531



Order

Catalog No.	
Series Name	No.
SNR12	7516

(SNR127516)

SNR12 Series is made to order.