

Slide Unit Inclined Pin Adjusting Type

FOR LOOSE CORE

RoHS

KOCUM

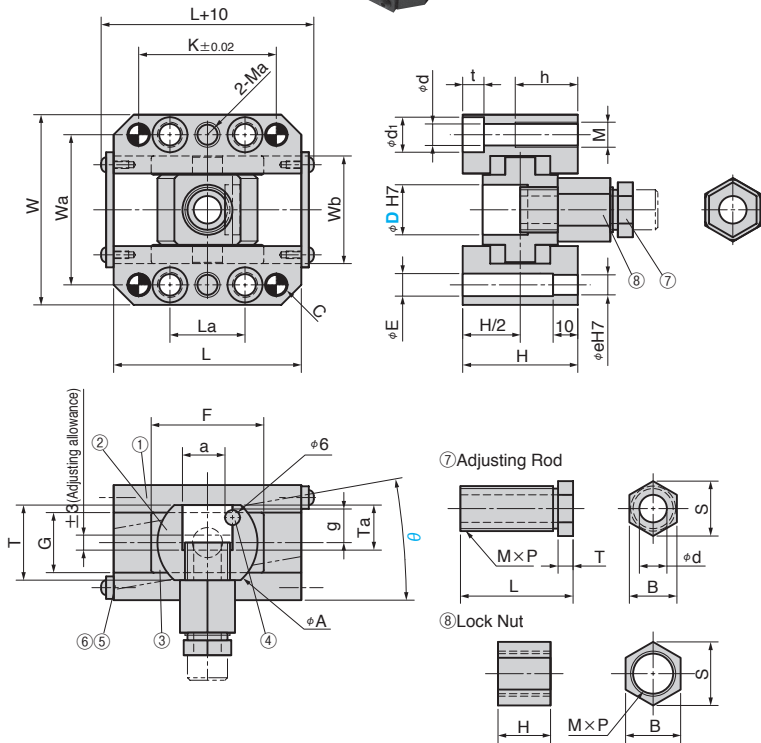
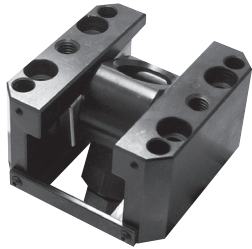

*Remove ⑤ Lock Plate as required for operation.

Table of Components

No.	Description	Qty	Material and Remark
①	Guide Rail	2	S45C (T C45 A 1045)
②	Inclined Pin Holder	1	S45C (T C45 A 1045)
③	Slide Plate	2	Bronze with Graphite
④	Loosening Lock	1	SK5M
⑤	Lock Plate	2	SS400 (A A36-89b, A283-88)
⑥	Round Head Screw	4	SCM435 (T 34CrMo4 A 4137)
⑦	Adjusting Rod	1	S45C (T C45 A 1045)
⑧	Lock Nut	1	S45C (T C45 A 1045)

D	W	Wa	L	La	K	Ma	Wb	C	d	d1	t	h	M	e	E	H
16	64	50	70	25	50	M 8	36	6	6.6	11	6.5	20	M 8	6	6.6	40
20	76	60	75	30	55	M10	43	8	8.6	14	8.5	25	M10	8	9	46
25	81	65	85	40	65	M10	48	8	8.6	14	8.5	25	M10	8	9	48
30	88	72	100	50	80	M10	55	8	8.6	14	8.5	25	M10	8	9	54
35	100	80	115	50	85	M12	64	8	11	(18)	6.5	30	M12	10	11	60
40	108	88	125	50	85	M12	72	8	11	(18)	7	30	M12	10	11	65

D	T	G	F	A	a	g	Ta
16	24	24	45	30	13	10	15
20	30	24	45	40	17	13	18
25	35	26	50	45	22	14	20.5
30	38	30	60	50	27	15	22
35	40	34	70	55	31	15	23
40	43	38	80	60	36	16	24.5

D	⑦ Adjusting Rod						⑧ Lock Nut		
	M×P	L	T	d	S	B	H	S	B
16	M14×1.5	42	6	9	16.2	14	21	19.6	17
20	M18×1.5	45	6	11	21.9	19	21	25.4	22
25	M22×1.5	49	7	13	25.4	22	21.5	31.2	27
30	M27×1.5	55	7	13	31.2	27	26	37.0	32
35	M30×1.5	58	7	13	37	32	28	41.6	36
40	M36×1.5	60.5	7	17	43.9	38	29	47.4	41

Catalog No.	D	θ
	16	Increments of 1° 0°~10°
	20	
KOCUM	25	
	30	
	35	
	40	



Order

Catalog No.	D	θ
KOCUM	25	0



Option

Option Code	Specification
G	Play of 0.1 to 0.2 is provided in the width direction (Wb).

Play of 0.1 to 0.2 is provided when the tolerance between dowel holes is ± 0. For details, refer to page. 74.



Order

KOCUM 25-0-G