

RCSUM

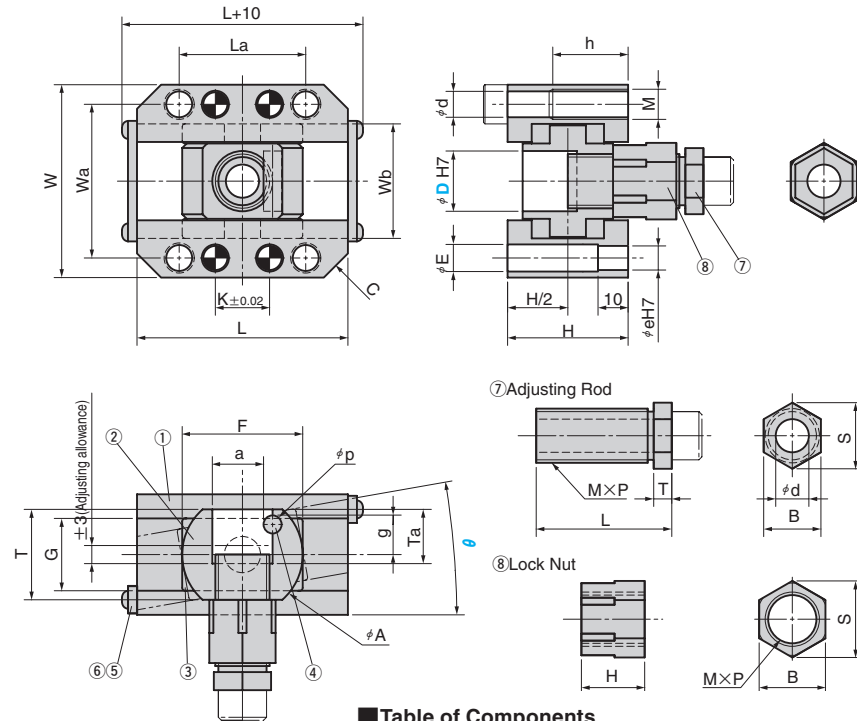
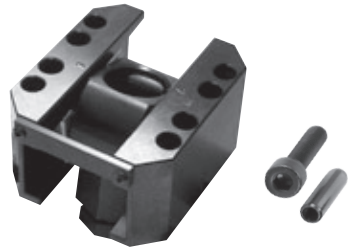

\*Remove ⑤ Lock Plate as required for operation.

Table of Components

No.	Description	Qty	Material and Remark
①	Guide Rail	2	S45C (A) C45 (A) 1045)
②	Inclined Pin Holder	1	S45C (A) C45 (A) 1045)
③	Slide Plate	2	Bronze with Graphite
④	Loosening Lock	1	SK5M
⑤	Lock Plate	2	SS400 (A) A36-89b, A283-88)
⑥	Round Head Screw	4	SCM435 (A) T 34CrMo4 (A) 4137)
⑦	Adjusting Rod	4	S45C (A) C45 (A) 1045)
⑧	Lock Nut	4	S45C (A) C45 (A) 1045)
⑨	Dowel Pin	4	SUJ2 (Accessories)
⑩	Mounting Bolt	4	SCM435 (Accessories)

D	W	Wa	L	K	La	Wb	C	d	M	h	e	E	H
16	54	44	65	18	38	33	8	6.6	M 8	20	6	6.6	35
20	64	51	70	18	42	38	8	8.6	M10	25	8	9	40
25	70	58	80	20	45	45	10	8.6	M10	25	8	9	44
30	78	64	100	40	70	51	8	8.6	M10	25	8	9	54
35	92	75	115	50	85	58	8	10.6	M12	30	10	11	60
40	100	82	125	50	85	66	8	10.6	M12	30	10	11	65

H Dimension (11° ≤ θ ≤ 20°)

D	T	G	F	A	p	a	g	Ta	D	11°~15°	16°~20°
16	24	20	40	30	6	13	10	15	16	41	48
20	30	24	40	40	6	17	13	18	20	47	55
25	35	26	45	45	6	22	14	20.5	25	52	61
30	38	30	55	50	6	27	15	22	30	62	72
35	40	34	70	55	8	31	15	23	35	70	82
40	43	38	70	60	8	36	16	24.5	40	78	90

D	M×P	⑦ Adjusting Rod						⑧ Lock Nut		
		L(Note)	T	d	S	B	H(Note)	S	B	
16	M14×1.5	42(50)	6	9	16.2	14	21(28)	19.6	17	
20	M18×1.5	45(54)	6	11	21.9	19	21(29)	25.4	22	
25	M22×1.5	49(59)	7	13	25.4	22	21.5(30.5)	31.2	27	
30	M27×1.5	54(64)	7	13	31.2	27	25(35)	37	32	
35	M30×1.5	58(68)	7	13	37	32	28(38)	41.6	36	
40	M36×1.5	60.5(70.5)	7	17	43.9	38	29(39)	47.3	41	

(Note) Values in columns L and H are dimensions when θ is 11° or more.

Catalog No.	D	θ
	16	Increments of 1°
	20	
RCSUM	25	0°~20°
	30	
	35	
	40	



Order

Catalog No.  D  -  θ



Option

Option Code	Specification
G	Play of 0.1 to 0.2 is provided in the width direction (Wb).

Play of 0.1 to 0.2 is provided when the tolerance between dowel holes is ± 0. For details, refer to page. 74.



Order

RCSUM 25-10-G