

# Inclined Pin Fitting Male Thread Type

FOR LOOSE CORE

RoHS

KOPB

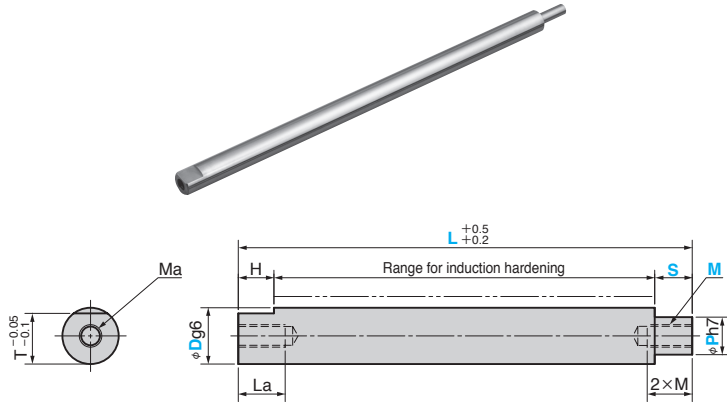

KOPBS (Two surfaces for loosening lock)

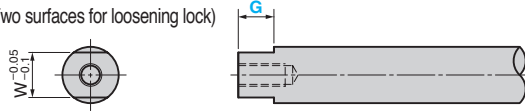

KOPNB (No machining for loosening lock)

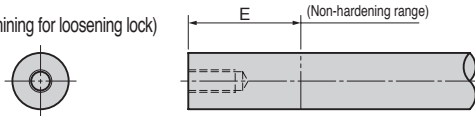

Material : SUJ2 (T B1 A 52100)  
 ---Area to be Induction Hardened  
 (HRC58 or more)  
 depth 0.8~2.0mm

D	g6	T	H	Ma × La	W	E
16	-0.006 -0.017	13	14	M8 × 20	10	30
20		17	17	M10 × 25	14	40
25	-0.007 -0.020	22	18		19	50
30		27	19	M12 × 25	24	
35	-0.009 -0.025	31	19		27	60
40		36	20	M16 × 35	32	

Catalog No.	D	L Increments of 1mm	S Increments of 1mm	P Selection	M Selection	G (KOPBS only)
	16			10	6	
				11 12	6 8	
				13	8 10	
	20			10	6	
				11 12 13	6 8	
				15 16	8 10	
KOPB KOPBS KOPNB	25	100~1000	P ≤ S ≤ (P × 4) L - H - S ≥ 10	12 13	6 8	H ≤ G ≤ E (increments of 1mm)
				15 16	8 10	
				18 20 22	10 12	
	30			15 16	8 10	
				18	10 12	
	35			20 22 24 25	12 16	
				18	10 12	
				20 22	12 16	
	40			24 25 28 30 32	16 20	
				20 22	12 16	
				24 25 28 30 32 36	16 20	



Order

Catalog No.	D	L	S	P	M	G
KOPB	16	300	S15	P12	M6	
KOPBS	25	600	S35	P20	M12	G40



Option

Option Code	Specification
YR	Non-hardening area is provided at the end of the induction hardening. (YR in the figure below)



Order

KOPB 16 - 300 - S15 - P12 - M6 - YR

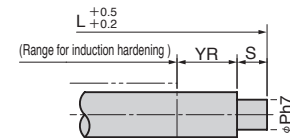

• Length at YR

D	φ8~φ16	φ20	φ25	φ30~
YR	30	40	50	60



Order method has changed

(Old) KOPB16-300-15-12-K6  
 (New) KOPB16-300-S15-P12-M6