

KOCUMR

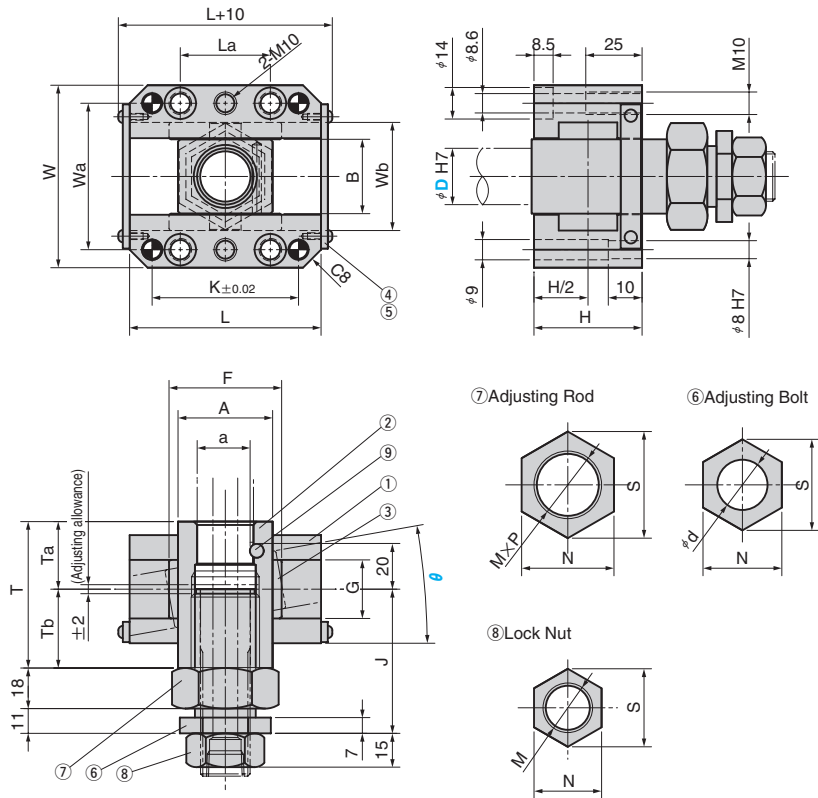

Table of Components

No.	Description	Qty	Material and Remark
①	Guide Rail	2	S45C (T C45 A 1045)
②	Inclined Pin Holder	1	S45C (T C45 A 1045)
③	Slide Plate	2	Bronze with Graphite
④	Lock Plate	2	SS400 (A A36-89b)
⑤	Round Head Screw	4	SCM435 (T 42CrMo4 A 4137)

No.	Description	Qty	Material and Remark
⑥	Adjusting Bolt	1	S45C (T C45 A 1045)
⑦	Adjusting Rod	1	S45C (T C45 A 1045)
⑧	Lock Nut	1	S45C (T C45 A 1045)
⑨	Loosening Lock	1	SK5M $\phi 6 \times 30$

D	W	Wa	L	K	La	B	Wb	H	A	a	T	Ta	Tb	F	G	J
25	81	65	85	65	40	33	48	48	40	23.5	60	26	34	50	26	63
30	88	72	100	80	50	38	55	54	47	28.5	67	29	38	60	30	67

⑥ Adjusting Bolt				⑦ Adjusting Rod			⑧ Lock Nut		
D	N	S	d	M×P	N	S	M	N	S
25	35	40.4	22.3	M30×P1.5	41	47.3	M22×1.5	32	37.0
30	38	43.9	27.3	M36×P1.5	46	53.1	M27×1.5	34	39.3

Catalog No.	D	θ Increments of 1°
KOCUMR	25	0°~10°
	30	

Order **Catalog No.** **D** - **θ**
KOCUMR 25 - 6

Option **Option Code** **Specification**
G Play of 0.1 to 0.2 is provided in the width direction (Wb).

Play of 0.1 to 0.2 is provided when the tolerance between dowel holes is ± 0 . For details, refer to page. 74.

Order **KOCUMR 25-6-G**

For the standard part of inclined pin with special cooling hole, refer to page.105.