

Ball Button · Press-Fit Button

FOR LOCATING

RoHS

BB

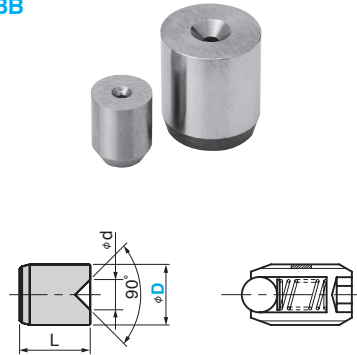

Material : SK4 (TC90 A W1-9)
Hardness : 60~62HRC

PFP

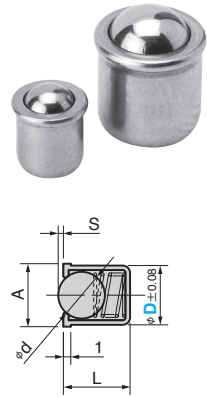

Material : Ball SUS304
(11 A 304)
Main unit SUS304
Hardness : 36~40HRC

D Tolerance	d	L	Catalog No.	D
4		1.5 5.0		4
5	+0.012 +0.004	2.0 6.0		5
6		2.0 8.0		6
8	+0.015 +0.006	3.0 10.0	BB	8
10		4.0 12.0		10
12	+0.018 +0.007	6.0 14.0		12
16		8.0 18.0		16

Order
BB 12

Travel S	L	A	d	Load N		Catalog No.	D
				Initial	Final		
0.8	5	4.6	3	2.5	6.0		4
1.0	6	5.6	4	3.0	6.5	PFP	5
1.6	7	6.5	5	5.5	11.5		6
1.9	9	8.5	6.3	7.0	12.5		8

Order
PFP 8

Wrench for plunger

PW



Material : S45C
(C45 A 1045)
Hardness : 36~40HRC
Surface treatment :
Black chromating

H	d	D	L	Catalog No.	Plunger M
40	3	6	40		5
40	3	6	40		6
45	4	8	45		8
45	4	10	45	PW	10
50	5	12	50		12
70	8	16	52		16
80	12	24	62		24
100	15	30	73		30

Order
PW 12